

StormTech® SC-740 Chamber

Designed to meet the most stringent industry performance standards for superior structural integrity while providing designers with a cost-effective method to save valuable land and protect water resources. The StormTech system is designed primarily to be used under parking lots, thus maximizing land usage for private (commercial) and public applications. StormTech chambers can also be used in conjunction with Green Infrastructure, thus enhancing the performance and extending the service life of these practices.

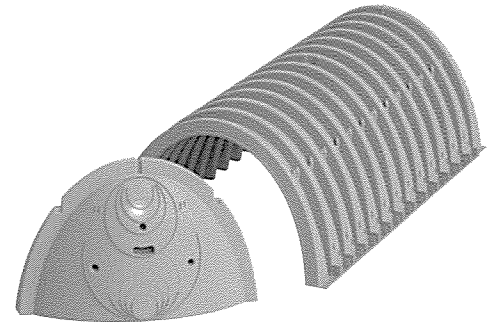

Nominal Chamber Specifications (not to scale)

Size (L x W x H)
85.4" x 51" x 30"
2,170 mm x 1,295 mm x 762 mm

Chamber Storage
45.9 ft³ (1.30 m³)

Min. Installed Storage*
74.9 ft³ (2.12 m³)

Weight
74.0 lbs (33.6 kg)

Shipping
30 chambers/pallet
60 end caps/pallet
12 pallets/truck

*Assumes 6" (150 mm) stone above, below and between chambers and 40% stone porosity.

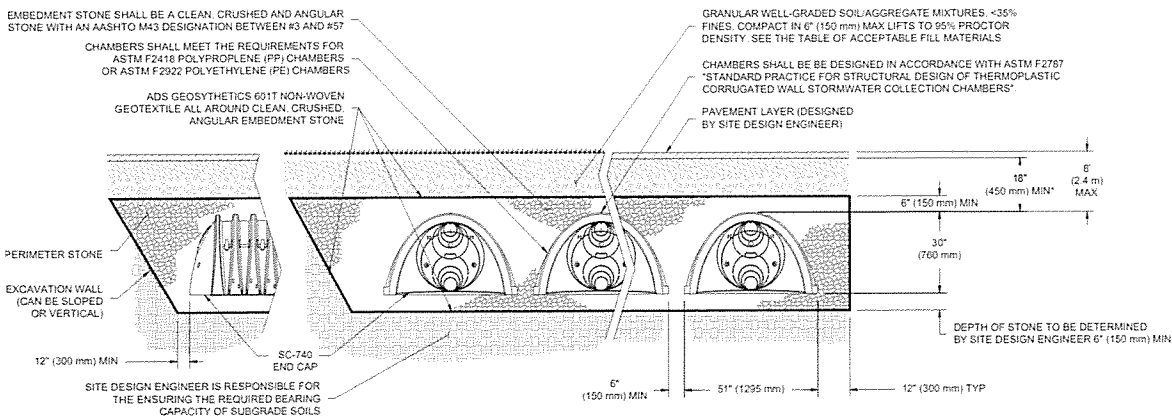
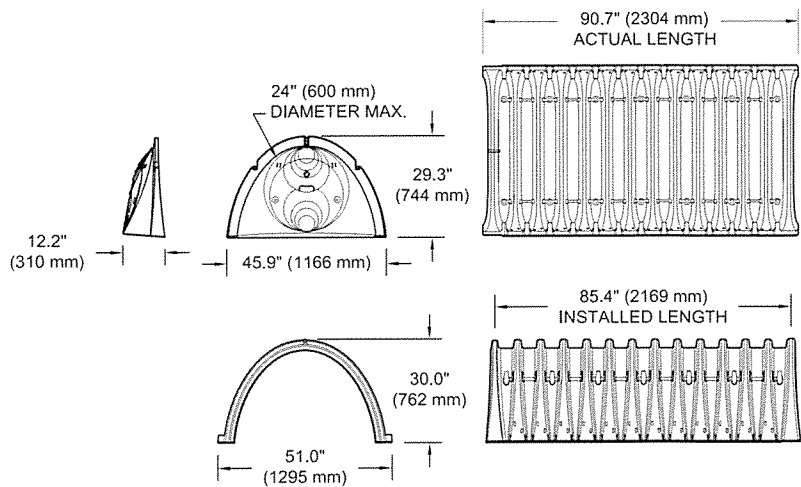

*MINIMUM COVER TO BOTTOM OF FLEXIBLE PAVEMENT. FOR UNPAVED INSTALLATIONS WHERE RUTTING FROM VEHICLES MAY OCCUR, INCREASE COVER TO 24" (600 mm)

StormTech SC-740 Specifications

Cumulative Storage Volumes Per Chamber

Assumes 40% Stone Porosity. Calculations are Based Upon a 6" (150 mm) Stone Base Under Chambers.

Depth of Water in System Inches (mm)	Cumulative Chamber Storage ft ³ (m ³)	Total System Cumulative Storage ft ³ (m ³)
42 (1067)	45.90 (1.300)	74.90 (2.121)
41 (1041)	45.90 (1.300)	73.77 (2.089)
40 (1016)	45.90 (1.300)	72.64 (2.057)
39 (991)	45.90 (1.300)	71.52 (2.025)
38 (965)	45.90 (1.300)	70.39 (1.993)
37 (940)	45.90 (1.300)	69.26 (1.961)
36 (914)	45.90 (1.300)	68.14 (1.929)
35 (889)	45.85 (1.298)	66.98 (1.897)
34 (864)	45.69 (1.294)	65.75 (1.862)
33 (838)	45.41 (1.286)	64.46 (1.825)
32 (813)	44.81 (1.269)	62.97 (1.783)
31 (787)	44.01 (1.246)	61.36 (1.737)
30 (762)	43.06 (1.219)	59.66 (1.689)
29 (737)	41.98 (1.189)	57.89 (1.639)
28 (711)	40.80 (1.155)	56.05 (1.587)
27 (686)	39.54 (1.120)	54.17 (1.534)
26 (660)	38.18 (1.081)	52.23 (1.479)
25 (635)	36.74 (1.040)	50.23 (1.422)
24 (610)	35.22 (0.977)	48.19 (1.365)
23 (584)	33.64 (0.953)	46.11 (1.306)
22 (559)	31.99 (0.906)	44.00 (1.246)
21 (533)	30.29 (0.858)	41.85 (1.185)
20 (508)	28.54 (0.808)	39.67 (1.123)
19 (483)	26.74 (0.757)	37.47 (1.061)
18 (457)	24.89 (0.705)	35.23 (0.997)
17 (432)	23.00 (0.651)	32.96 (0.939)
16 (406)	21.06 (0.596)	30.68 (0.869)
15 (381)	19.09 (0.541)	28.36 (0.803)
14 (356)	17.08 (0.484)	26.03 (0.737)
13 (330)	15.04 (0.426)	23.68 (0.670)
12 (305)	12.97 (0.367)	21.31 (0.608)
11 (279)	10.87 (0.309)	18.92 (0.535)
10 (254)	8.74 (0.247)	16.51 (0.468)
9 (229)	6.58 (0.186)	14.09 (0.399)
8 (203)	4.41 (0.125)	11.66 (0.330)
7 (178)	2.21 (0.063)	9.21 (0.264)
6 (152)	0 (0)	6.76 (0.191)
5 (127)	0 (0)	5.63 (0.160)
4 (102)	0 (0)	4.51 (0.128)
3 (76)	0 (0)	3.38 (0.096)
2 (51)	0 (0)	2.25 (0.064)
1 (25)	0 (0)	1.13 (0.032)

Stone Cover

Stone Foundation

Note: Add 1.13 ft³ (0.032 m³) of storage for each additional inch (25 mm) of stone foundation.

ADS StormTech products, manufactured in accordance with ASTM F2418 or ASTM F2922, comply with all requirements in the Build America, Buy America (BABA) Act.

Working on a project?

Visit us at adspipe.com/stormtech and utilize the Design Tool

Storage Volume Per Chamber ft³ (m³)

	Bare Chamber Storage ft ³ (m ³)	Chamber and Stone Foundation Depth in. (mm)		
		6 (150)	12 (300)	18 (450)
SC-740 Chamber	45.9 (1.3)	74.9 (2.1)	81.7 (2.3)	88.4 (2.5)

Note: Assumes 6" (150 mm) stone above chambers, 6" (150 mm) row spacing and 40% stone porosity.

Amount of Stone Per Chamber

English Tons (yds ³)	Stone Foundation Depth		
	6"	12"	16"
SC-740	3.8 (2.8)	4.6 (3.3)	5.5 (3.9)
Metric Kilograms (m ³)	150 mm	300 mm	450 mm
SC-740	3,450 (2.1)	4,170 (2.5)	4,490 (3.0)

Note: Assumes 6" (150 mm) of stone above and between chambers.

Volume Excavation Per Chamber yd³ (m³)

	Stone Foundation Depth		
	6 (150)	12 (300)	18 (450)
SC-740	5.5 (4.2)	6.2 (4.7)	6.8 (5.2)

Note: Assumes 6" (150 mm) of row separation and 18" (450 mm) of cover. The volume of excavation will vary as depth of cover increases.

