

# SC-160LP, SC-310, SC-740 & DC-780 Design Manual

StormTech® Chamber Systems for Stormwater Management

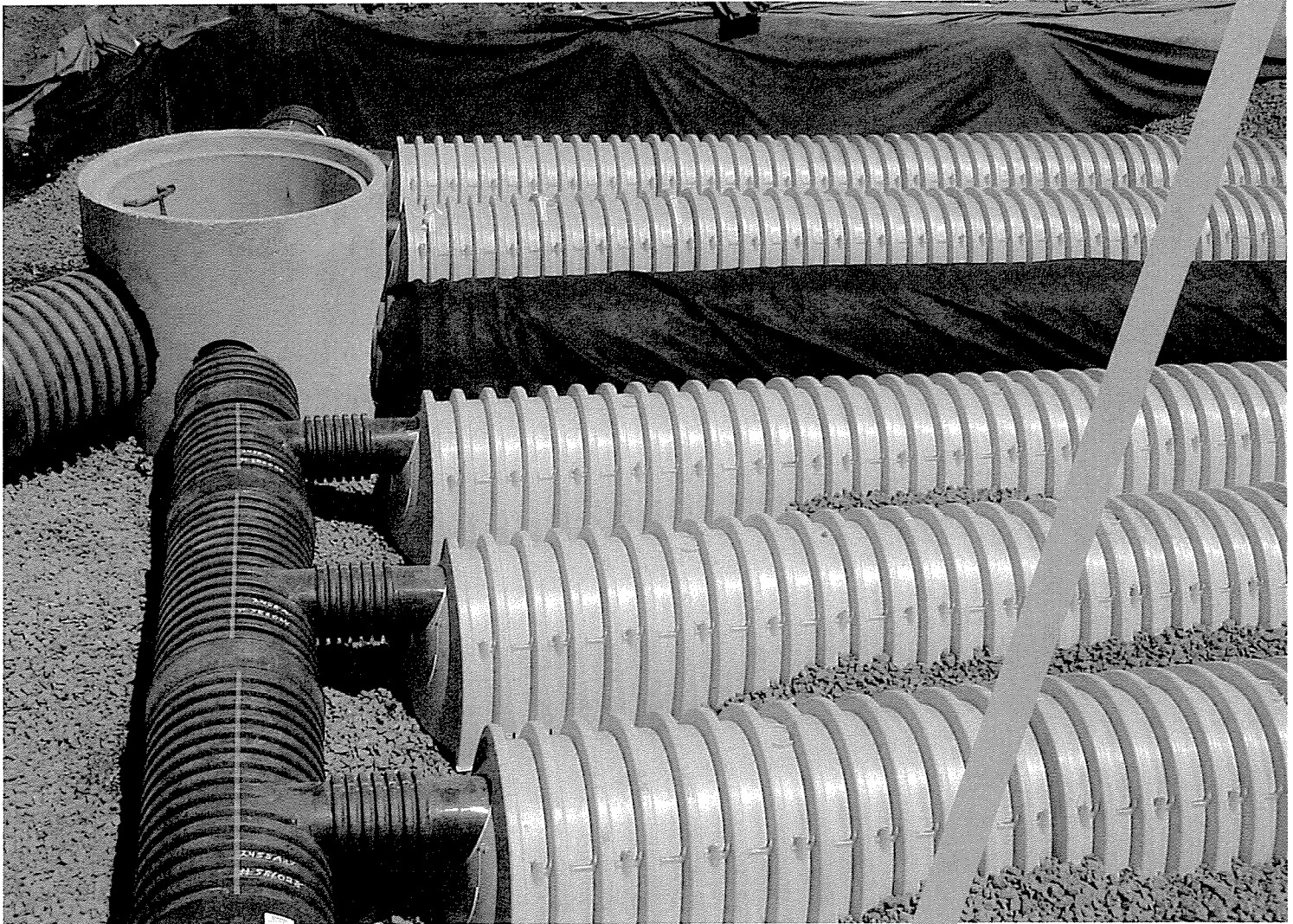

**///ADS**  
StormTech™



# 1.0 Introduction

## 1.1 Introduction

StormTech stormwater management systems allow storm water professionals to create more profitable, environmentally sound developments. Compared with other subsurface systems, StormTech systems offer lower overall installed cost, superior design flexibility and enhanced performance. Applications include commercial, residential, agricultural and highway drainage.

StormTech has invested over \$10 million and many years in the development of StormTech chambers. These innovative products exceed the rigorous requirements of the standards governing the design of thermoplastic structures.

## 1.2 Gold Standard in Stormwater Management

The advanced designs of StormTech chambers were created by implementing an aggressive research, development, design and manufacturing protocol. StormTech chamber products establish the new gold standard in stormwater management through:

- Collaborations with experts in the field of buried plastic structures and polyolefin materials
- The development and utilization of new testing methods and proprietary test methods
- The use of thermoformed prototypes to verify engineering models, perform in-ground testing and install observation sites
- The investment in custom-designed, injection molding equipment
- The utilization of polypropylene and polyethylene as manufacturing materials
- The design of molded-in features not possible with traditional thermoformed chambers

Section 3.0 of this design manual, Structural Capabilities, provides a detailed description of the research, development and design process.

Many of StormTech's unique chamber features can benefit a site developer, stormwater system designer, and installer. Where applicable, StormTech Product Specifications are referenced throughout this design manual. If StormTech's unique product benefits are important to a stormwater system design, consider including the applicable StormTech Product Specifications on the site plans. This can prevent substitutions with inferior products. Refer to Section 14.0, *StormTech Product Specifications*.

## 1.3 Product Quality and Design to International Standards

StormTech chambers are designed to meet the full scope of design requirements of Section 12.12 of the AASHTO LRFD Bridge Design Specifications and produced to the requirements of the American

Society of Testing Materials (ASTM) International specifications F2418 (polypropylene chambers) and F2922 (polyethylene chambers).

StormTech chambers provide the full AASHTO safety factors for live loads and permanent earth loads. The two ASTM standards mentioned previously are linked to the AASHTO LRFD Bridge Design Specifications Section 12.12 design standard. Both ASTM standards require that the safety factors included in the AASHTO guidance are achieved as a prerequisite to meeting either ASTM F2418 or ASTM F2922. StormTech chambers are also designed in accordance with ASTM F2787, Standard Practice for Structural Design of Thermoplastic Corrugated Wall Stormwater Collection Chambers which provides specific guidance on how to design thermoplastic chambers in accordance with AASHTO Section 12.12. These standards provide both the assurance of product quality and safe structural design.

For non-proprietary specifications for public bids that ensure high product quality and safe design, consider including the specification in Section 15.0 Chamber Specifications for Contract Documents.

## 1.4 Technical Support for Plan Reviews

StormTech's in-house technical support staff is available to review proposed plans that incorporate StormTech chamber systems. They are also available to assist with plan conversions from existing products to StormTech. Not all plan sheets are necessary for StormTech's review. Required sheets include plan view sheet(s) with design contours, cross sections of the stormwater system including catch basins and drainage details.

When specifying StormTech chambers it is recommended that the following items are included in project plans: StormTech chamber system General Notes, applicable StormTech chamber illustrations and StormTech chamber system Product Specifications. These items are available in various formats and can be obtained by contacting StormTech at **1-860-529-8188** or may be downloaded at **www.stormtech.com**.

StormTech's plan review is limited to the sole purpose of determining whether plans meet StormTech chamber systems' minimum requirements. **It is the ultimate responsibility of the design engineer to assure that the stormwater system's design is in full compliance with all applicable laws and regulations.** StormTech products must be designed and installed in accordance with StormTech's minimum requirements.

### Send Plans to:

E-mail: [info@stormtech.com](mailto:info@stormtech.com).

## 2.0 Product Information

### 2.1 Product Applications

StormTech chamber systems may function as stormwater detention, retention, first-flush storage, or some combination of these. The StormTech chambers can be used for commercial, municipal, industrial, recreational, and residential applications especially for installations under parking lots and commercial roadways.

One of the key advantages of the StormTech chamber system is its design flexibility. Chambers may be configured into beds or trenches of various sizes or shapes. They can be centralized or decentralized, and fit on nearly all sites. Chamber lengths enhance the ability to develop on both existing and pre-developed projects. The systems can be designed easily and efficiently around utilities, natural or man-made structures and any other limiting boundaries.

### 2.2 Chambers for Stormwater Detention

Chamber systems have been used effectively for storm water detention for over 15 years. A detention system temporarily holds water while it is released at a defined rate through an outlet. While some infiltration may occur in a detention system, it is often considered an environmental benefit and a storage safety factor. Over 70% of StormTech's installations are non-watertight detention systems. There are only a few uncommon situations where a detention system might need to limit infiltration: the subgrade soil's bearing capacity is significantly affected by saturation such as with expansive clays or karst soils, and; in sensitive aquifer areas where the depth to groundwater does not meet local guidelines. Adequate pretreatment could eliminate concerns for the latter case. A thermoplastic liner may be considered for both situations to limit infiltration.

### 2.3 Stone Porosity Assumption

A StormTech chamber system requires the application of clean, crushed, angular stone below, between and above the chambers. This stone serves as a structural component while allowing conveyance and storage of stormwater. Storage volume examples throughout this Design Manual are calculated with an assumption that the stone has an industry standard porosity of 40%. Actual stone porosity may vary. Contact StormTech for information on calculating storm water volumes with varying stone porosity assumptions.

### 2.4 Chamber Selection

Primary considerations when selecting between the SC-160LP, SC-310, SC-740 and DC-780 chambers are the depth to restrictive layer, available area for subsurface storage, cover height and outfall restrictions.



**StormTech systems can be integrated into retrofit and new construction projects.**

The StormTech SC-160LP chamber shown on page 4 is the smallest of the chamber family and has been optimized to fit in the shallowest of applications. This extra low profile chamber allows for storage of 1.01 ft<sup>3</sup>/ft<sup>2</sup> (0.3m<sup>3</sup>/m<sup>2</sup>) [minimum] of storage.

The StormTech SC-310 chamber shown on page 6 is ideal for systems requiring low-rise and wide-span solutions. This low profile chamber allows the storage of large volumes, 1.3 ft<sup>3</sup>/ft<sup>2</sup> (0.40 m<sup>3</sup>/m<sup>2</sup>) [minimum], at minimum depths.

Like the Stormtech SC-310, the StormTech SC-310-3 found on page 8 allows for a design option for sites with both limited cover and limited space. With only 3 of spacing between the chambers, the SC-310-3 still provides 1.3 ft<sup>3</sup>/ft<sup>2</sup> (0.40 m<sup>3</sup>/m<sup>2</sup>) [minimum] of storage.

The StormTech SC-740 chamber shown on page 10 optimizes storage volumes in relatively small footprints. By providing 2.2 ft<sup>3</sup>/ft<sup>2</sup> (0.67 m<sup>3</sup>/m<sup>2</sup>) [minimum] of storage, the SC-740 chambers can minimize excavation, backfill and associated costs.

The DC-780 chamber shown on page 12 has been developed for those applications which exceed the maximum 8 ft (2.44 m) burial depth of the SC-740 and SC-310 chambers. The DC-780 is a modified version of the SC-740 allowing it to reach a maximum burial depth of 12 ft (3.66 m). The design of the DC-780 chamber, like other StormTech chambers, is designed and manufactured in accordance with the AASHTO LRFD Bridge Design Specifications as well as ASTM F 2418 and ASTM F 2787 ensuring structural adequacy for deeper systems.

The end corrugations of the DC-780 chamber have not been modified in order to allow connections to the SC-740 chamber. This will allow hybrid systems utilizing both chambers in one system design.

# SC-160LP Chamber

Designed to meet the most stringent industry performance standards for superior structural integrity while providing designers with a cost-effective method to save valuable land and protect water resources. The StormTech system is designed primarily to be used under parking lots, thus maximizing land usage for commercial and municipal applications. StormTech chambers can also be used in conjunction with Green Infrastructure, thus enhancing the performance and extending the service life of these practices.

The SC-160LP chamber was developed for infiltration and detention in shallow cover applications

- Only 14" (350 mm) required from top of chamber to bottom of pavement
- Only 12" (300 mm) tall
- Installs toe to toe—no additional spacing between rows

## SC-160LP Chamber (not to scale)

Nominal Specifications

|                         |  |
|-------------------------|--|
| Size (LxWxH)            | 85.4" x 25.0" x 12.0"<br>(2170 x 635 x 305 mm) |
| Chamber Storage         | 6.85 ft <sup>3</sup> (0.19 m <sup>3</sup> )    |
| Min. Installed Storage* | 15.0 ft <sup>3</sup> (0.42 m <sup>3</sup> )    |
| Weight                  | 24.0 lbs. (10.9 kg)                            |

\*Assumes 6 (150 mm) stone above, 4 (100 mm) below and stone between chambers with 40% stone porosity

## Shipping

132 chambers/pallet

144 end caps/pallet

12 pallets/truck

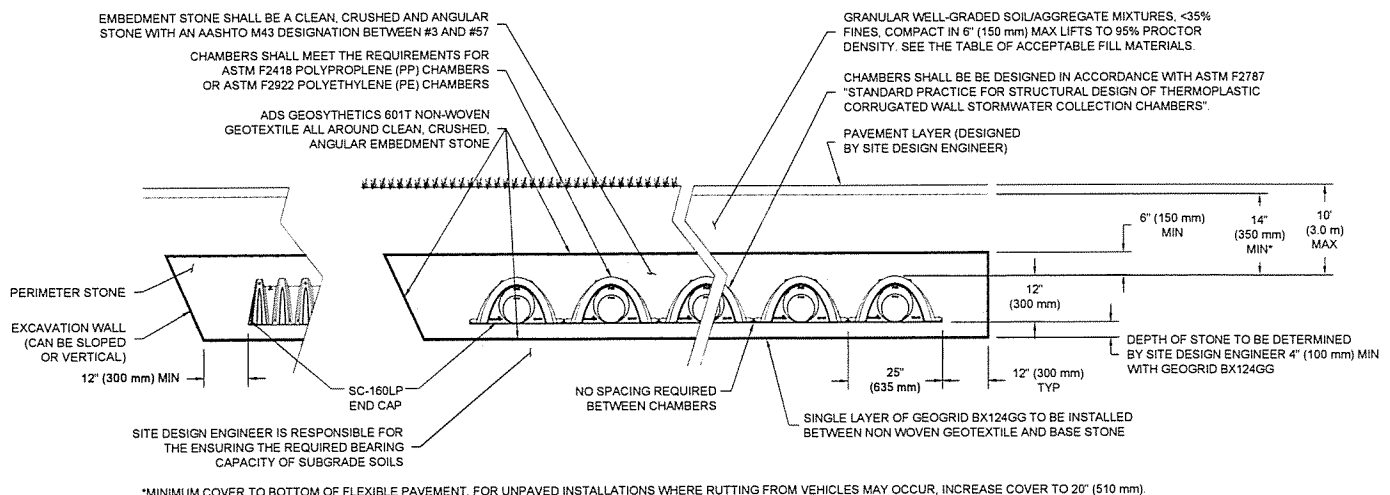
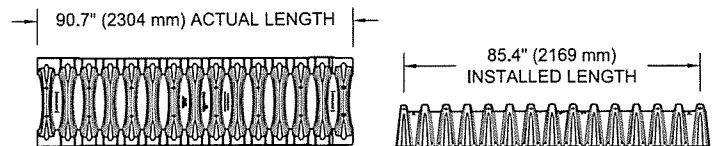
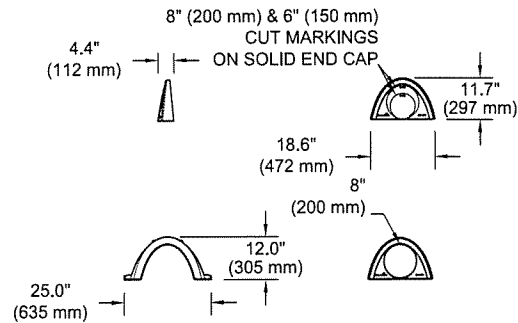
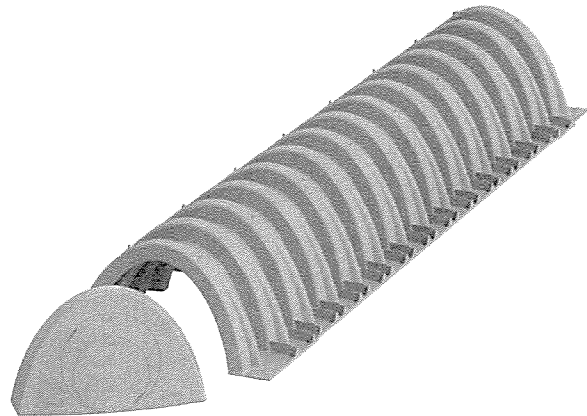

\*MINIMUM COVER TO BOTTOM OF FLEXIBLE PAVEMENT. FOR UNPAVED INSTALLATIONS WHERE RUTTING FROM VEHICLES MAY OCCUR, INCREASE COVER TO 20" (510 mm).

The installed chamber system shall provide the load factors specified in the aashto lrfd bridge design specifications section 12.12 for earth and live loads, with consideration for impact and multiple vehicle presences.

### SC-160LP Cumulative Storage Volumes per chamber

Assumes 40% Stone Porosity. Calculations are based upon a 4" (100 mm) Stone Base Under Chambers.

| Depth of Water in System in. (mm) |  | Cumulative Chamber Storage ft <sup>3</sup> (m <sup>3</sup> ) | Total System Cumulative Storage ft <sup>3</sup> (m <sup>3</sup> ) |
|-----------------------------------|--|--|---|
| 22 (559)                          |  | 6.85 (0.194)   | 14.98 (0.424)   |
| 21 (533)                          |  | 6.85 (0.194)   | 14.49 (0.410)   |
| 20 (508)                          |  | 6.85 (0.194)   | 14.00 (0.396)   |
| 19 (483)                          |  | 6.85 (0.194)   | 13.50 (0.382)   |
| 18 (457)                          |  | 6.85 (0.194)   | 13.01 (0.368)   |
| 17 (432)                          |  | 6.85 (0.194)   | 12.51 (0.354)   |
| 16 (406)                          |  | 6.85 (0.194)   | 12.02 (0.340)   |
| 15 (381)                          |  | 6.80 (0.193)   | 11.49 (0.325)   |
| 14 (356)                          |  | 6.67 (0.189)   | 10.92 (0.309)   |
| 13 (330)                          |  | 6.38 (0.181)   | 10.25 (0.290)   |
| 12 (305)                          |  | 5.94 (0.168)   | 9.49 (0.269)  |
| 11 (279)                          |  | 5.40 (0.153)   | 8.67 (0.246)  |
| 10 (254)                          |  | 4.78 (0.135)   | 7.81 (0.221)  |
| 9 (229)                           |  | 4.10 (0.116)   | 6.91 (0.196)  |
| 8 (203)                           |  | 3.36 (0.095)   | 5.97 (0.169)  |
| 7 (178)                           |  | 2.58 (0.073)   | 5.01 (0.142)  |
| 6 (152)                           |  | 1.76 (0.050)   | 4.02 (0.114)  |
| 5 (127)                           |  | 0.89 (0.025)   | 3.01 (0.085)  |
| 4 (102)                           |  | 0 (0)  | 1.98 (0.056)  |
| 3 (76)                            |  | 0 (0)  | 1.48 (0.042)  |
| 2 (51)                            |  | 0 (0)  | 0.99 (0.028)  |
| 1 (25)                            |  | 0 (0)  | 0.49 (0.014)  |

↑  
Stone  
Cover  
↓

↑  
Stone  
Foundation  
↓

**Note:** Add 0.49 ft<sup>3</sup> (0.014 m<sup>3</sup>) of storage for each additional inch (25 mm) of stone foundation.

### Amount of Stone Per Chamber

| TONS (yds <sup>3</sup> )    | Stone Foundation Depth |             |             |
|-----------------------------|------------------------|-------------|-------------|
|                             | 4                      | 6           | 8           |
| SC-160LP                    | 1.1 (0.8)              | 1.2 (0.9)   | 1.3 (0.9)   |
| KILOGRAMS (m <sup>3</sup> ) | 100 mm                 | 150 mm      | 200 mm      |
| SC-160LP                    | 952 (0.7)              | 1,074 (0.8) | 1,197 (0.8) |

**Note:** Assumes 6 (150 mm) of stone above and only embedment stone between chambers.

### Volume Excavation Per Chamber yd<sup>3</sup> (m<sup>3</sup>)

| Yards <sup>3</sup> (m <sup>3</sup> ) | Stone Foundation Depth |           |           |
|--------------------------------------|------------------------|-----------|-----------|
|                                      | 4 (100)                | 8 (200)   | 12 (300)  |
| SC-160LP                             | 1.4 (1.1)              | 1.6 (1.2) | 1.8 (1.3) |

**Note:** Assumes no row separation and 14 (350 mm) of cover. The volume of excavation will vary as depth of cover increases.

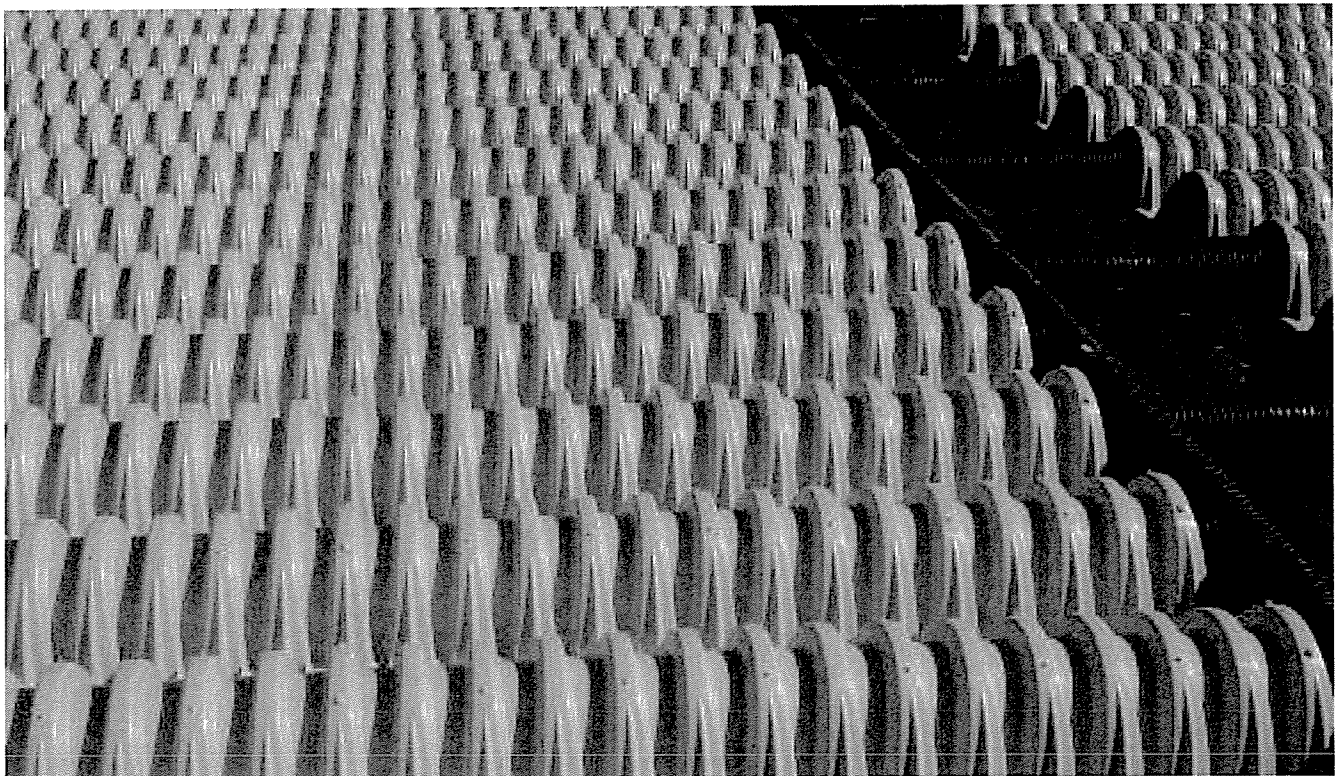

# SC-310 Chamber

Designed to meet the most stringent industry performance standards for superior structural integrity while providing designers with a cost-effective method to save valuable land and protect water resources. The StormTech system is designed primarily to be used under parking lots, thus maximizing land usage for private (commercial) and public applications. StormTech chambers can also be used in conjunction with Green Infrastructure, thus enhancing the performance and extending the service life of these practices.

## SC-310 Chamber (not to scale)

### Nominal Specifications

|                         |  |
|-------------------------|--|
| Size (L x W x H)        | 85.4" x 34.0" x 16.0"<br>(2170 x 864 x 406 mm) |
| Chamber Storage         | 14.7 ft <sup>3</sup> (0.42 m <sup>3</sup> )    |
| Min. Installed Storage* | 31.0 ft <sup>3</sup> (0.88 m <sup>3</sup> )    |
| Weight                  | 37.0 lbs (16.8 kg)                             |

\*Assumes 6 (150 mm) stone above, below and between chambers and 40% stone porosity.

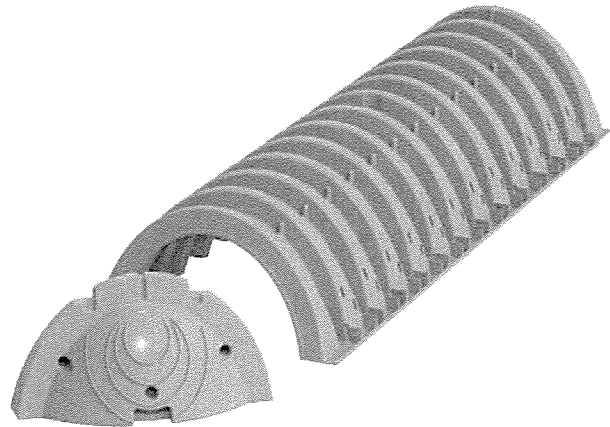

## Shipping

41 chambers/pallet

108 end caps/pallet

18 pallets/truck

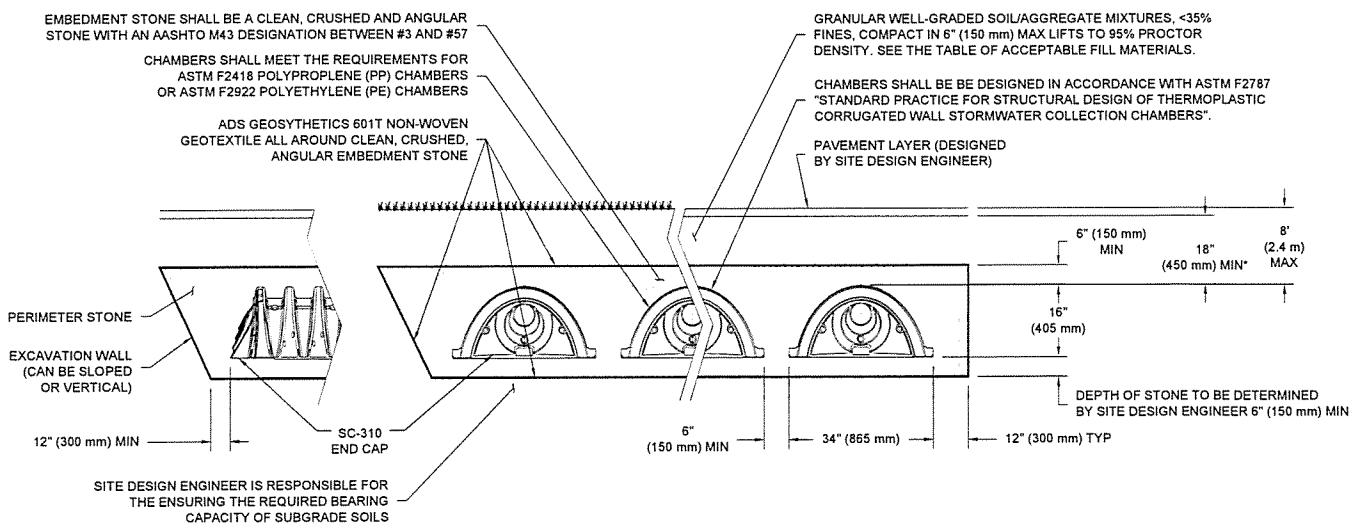
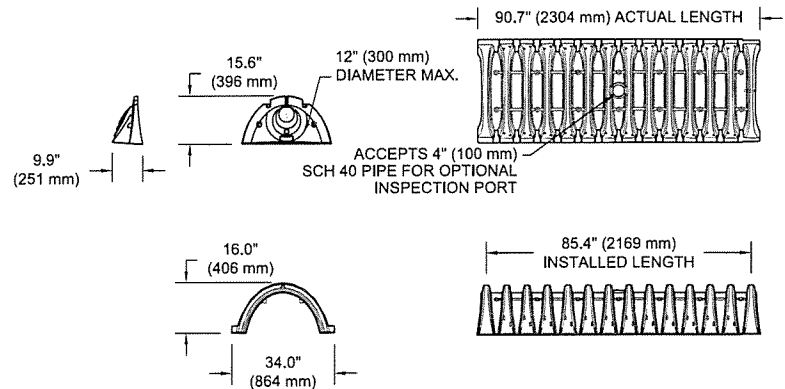

\*MINIMUM COVER TO BOTTOM OF FLEXIBLE PAVEMENT. FOR UNPAVED INSTALLATIONS WHERE RUTTING FROM VEHICLES MAY OCCUR, INCREASE COVER TO 24" (600 mm).

The installed chamber system shall provide the load factors specified in the aashto lfrd bridge design specifications section 12.12 for earth and live loads, with consideration for impact and multiple VEHICLE presences.

**SC-310 Cumulative Storage Volumes per Chamber**  
Assumes 40% Stone Porosity. Calculations are Based Upon a 6 (150 mm) Stone Base Under Chambers.

| Depth of Water in System Inches (mm) | Cumulative Chamber Storage ft <sup>3</sup> (m <sup>3</sup> ) | Total System Cumulative Storage ft <sup>3</sup> (m <sup>3</sup> ) |
|--------------------------------------|--|---|
| 28 (711)                             | 14.70 (0.416)  | 31.00 (0.878)   |
| 27 (686)                             | 14.70 (0.416)  | 30.21 (0.855)   |
| 26 (680)                             | 14.70 (0.416)  | 29.42 (0.833)   |
| 25 (610)                             | 14.70 (0.416)  | 28.63 (0.811)   |
| 24 (609)                             | 14.70 (0.416)  | 27.84 (0.788)   |
| 23 (584)                             | 14.70 (0.416)  | 27.05 (0.766)   |
| 22 (559)                             | 14.70 (0.416)  | 26.26 (0.748)   |
| 21 (533)                             | 14.64 (0.415)  | 25.43 (0.720)   |
| 20 (508)                             | 14.49 (0.410)  | 24.54 (0.695)   |
| 19 (483)                             | 14.22 (0.403)  | 23.58 (0.668)   |
| 18 (457)                             | 13.68 (0.387)  | 22.47 (0.636)   |
| 17 (432)                             | 12.99 (0.368)  | 21.25 (0.602)   |
| 16 (406)                             | 12.17 (0.345)  | 19.97 (0.566)   |
| 15 (381)                             | 11.25 (0.319)  | 18.62 (0.528)   |
| 14 (356)                             | 10.23 (0.290)  | 17.22 (0.488)   |
| 13 (330)                             | 9.15 (0.260)   | 15.78 (0.447)   |
| 12 (305)                             | 7.99 (0.227)   | 14.29 (0.425)   |
| 11 (279)                             | 6.78 (0.192)   | 12.77 (0.362)   |
| 10 (254)                             | 5.51 (0.156)   | 11.22 (0.318)   |
| 9 (229)                              | 4.19 (0.119)   | 9.64 (0.278)  |
| 8 (203)                              | 2.83 (0.081)   | 8.03 (0.227)  |
| 7 (178)                              | 1.43 (0.041)   | 6.40 (0.181)  |
| 6 (152)                              | 0  | 4.74 (0.134)  |
| 5 (127)                              | 0  | 3.95 (0.112)  |
| 4 (102)                              | 0  | 3.16 (0.090)  |
| 3 (76)                               | 0  | 2.37 (0.067)  |
| 2 (51)                               | 0  | 1.58 (0.046)  |
| 1 (25)                               | 0  | 0.79 (0.022)  |

Stone Cover

Stone Foundation

**Note:** Add 0.79 ft<sup>3</sup> (0.022 m<sup>3</sup>) of storage for each additional inch. (25 mm) of stone foundation.

**Storage Volume Per Chamber**

| ft <sup>3</sup> (m <sup>3</sup> ) | Bare Chamber Storage ft <sup>3</sup> (m <sup>3</sup> ) | Chamber and Stone Foundation Depth in. (mm) |            |            |
|-----------------------------------|--|---|------------|------------|
|                                   |  | 6 (150)                                     | 12 (300)   | 18 (450)   |
| SC-310                            | 14.7 (0.4)   | 31.0 (0.9)                                  | 35.7 (1.0) | 40.4 (1.1) |

**Note:** Assumes 6 (150 mm) of stone above chambers, 6" (150 mm) row spacing and 40% stone porosity.

**Amount of Stone Per Chamber**

| TONS (yds <sup>3</sup> ) | Stone Foundation Depth |           |           |
|--------------------------|------------------------|-----------|-----------|
|                          | 6"                     | 12"       | 18"       |
| SC-310                   | 2.1 (1.5)              | 2.7 (1.9) | 3.4 (2.4) |

| KILOGRAMS (m <sup>3</sup> ) | Stone Foundation Depth |             |             |
|-----------------------------|------------------------|-------------|-------------|
|                             | 150 mm                 | 300 mm      | 450 mm      |
| SC-310                      | 1,830 (1.1)            | 2,490 (1.5) | 2,990 (1.8) |

**Note:** Assumes 6 (150 mm) of stone above, and between chambers.

**Volume Excavation Per Chamber**

| yd <sup>3</sup> (m <sup>3</sup> ) | Stone Foundation Depth |             |             |
|-----------------------------------|------------------------|-------------|-------------|
|                                   | 6 (150 mm)             | 12 (300 mm) | 18 (450 mm) |
| SC-310                            | 2.9 (2.2)              | 3.4 (2.6)   | 3.8 (2.9)   |

**Note:** Assumes 6 (150 mm) of row separation and 18" (450 mm) of cover. The volume of excavation will vary as the depth of the cover increases.

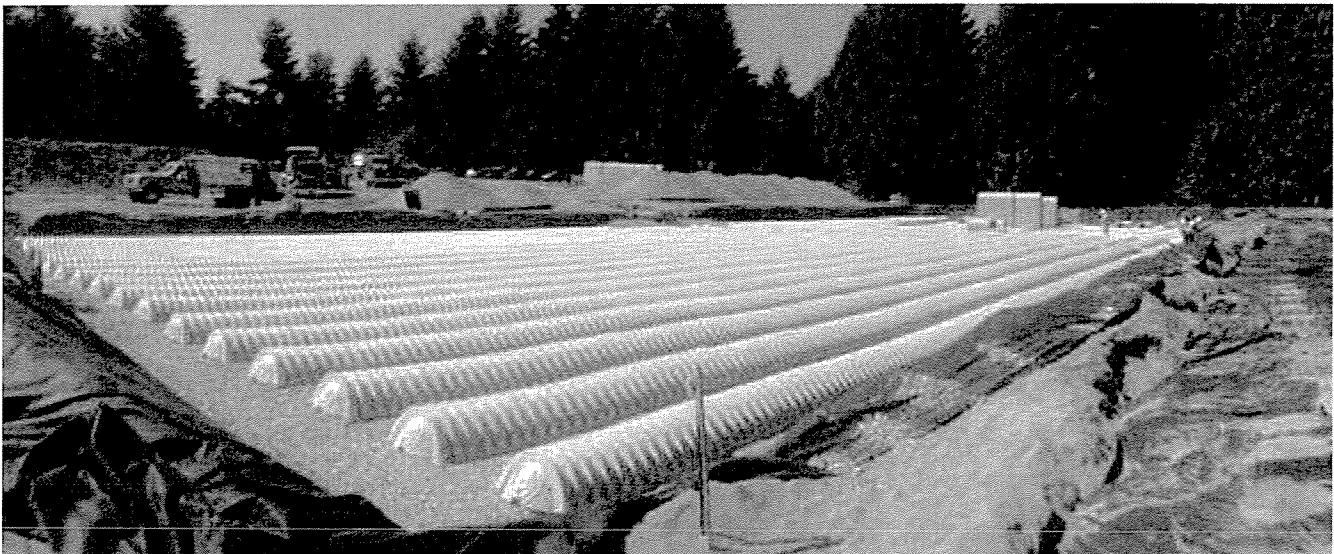



# SC-310-3 Chamber

The proven strength and durability of the SC-310-3 Chamber allows for a design option for sites where limited cover, limited space, high water table and escalated aggregate cost are a factor. The SC-310-3 has a minimum cover requirement of 16 (400 mm) to bottom of flexible pavement and reduces the spacing requirement between chambers by 50% to 3 (76 mm). This provides a reduced footprint overall, reduces aggregate needed, and allows the designer to offer a traffic bearing application yet comply with water table separation regulations. StormTech chambers can also be used in conjunction with Green Infrastructure, thus enhancing the performance and extending the service life of these practices.

## SC-310-3 Chamber (not to scale)

Nominal Specifications

|                         |   |
|-------------------------|---|
| Size (Lx W x H)         | 85.4" x 34.0" x 16.0"<br>(2,170 x 864 x 406 mm) |
| Chamber Storage         | 14.7ft <sup>3</sup> (0.42 m <sup>3</sup> )      |
| Min. Installed Storage* | 29.3 ft <sup>3</sup> (0.83 m <sup>3</sup> )     |
| Weight                  | 37.0 lbs (16.8 kg)                              |

\*Assumes 6 (150 mm) stone above and below chambers, 3 (76 mm) row spacing and 40% stone porosity.

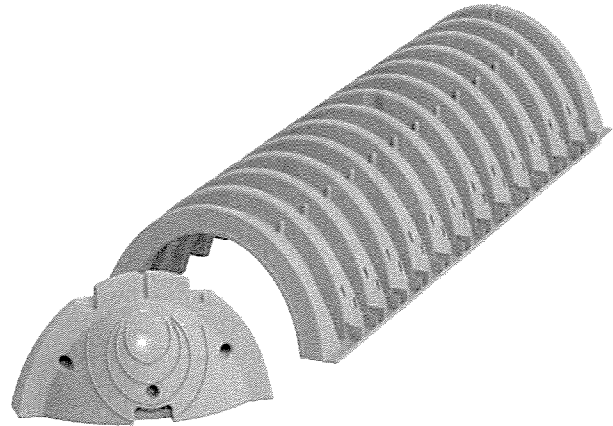

## Shipping

41 chambers/pallet

108 end caps/pallet

18 pallets/truck

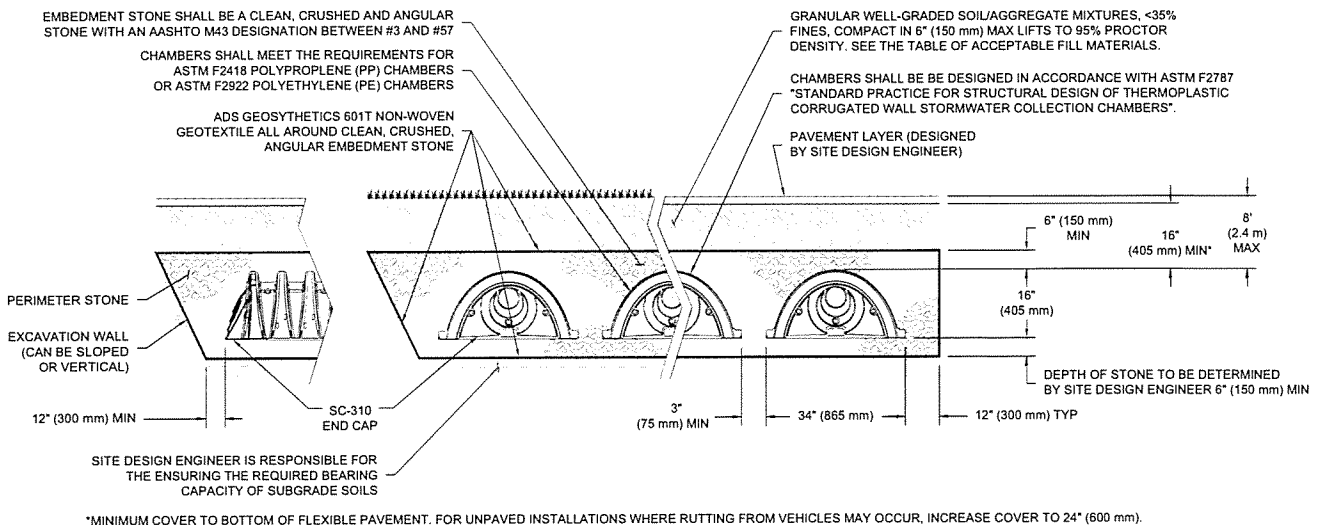
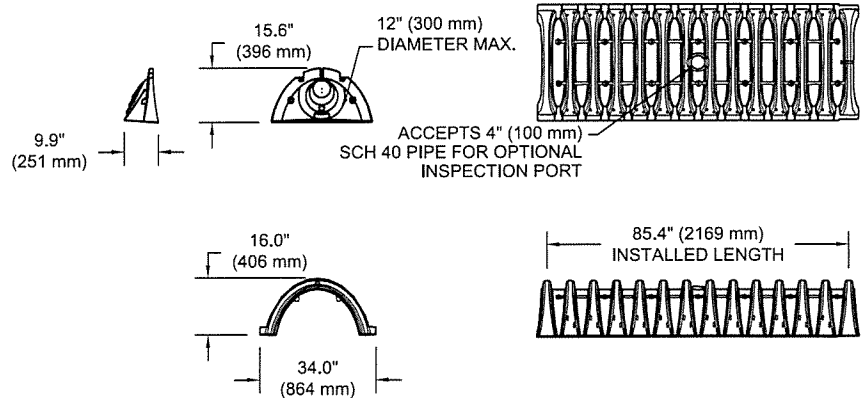

The installed chamber system shall provide the load factors specified in the aashto lrfd bridge design specifications section 12.12 for earth and live loads, with consideration for impact and multiple vehicle presences.

**SC-310-3 Cumulative Storage Volumes per chamber**  
Assumes 40% Stone Porosity. Calculations are Based Upon a 6" (150 mm) Stone Base Under Chambers.

| Depth of Water in System in. (mm) | Cumulative Chamber Storage ft <sup>3</sup> (m <sup>3</sup> ) | Total System Cumulative Storage ft <sup>3</sup> (m <sup>3</sup> ) |
|-----------------------------------|--|---|
| 28 (711)                          | 14.70 (0.416)  | 29.34 (0.831)   |
| 27 (686)                          | 14.70 (0.416)  | 28.60 (0.810)   |
| 26 (660)                          | 14.70 (0.416)  | 27.87 (0.789)   |
| 25 (635)                          | 14.70 (0.416)  | 27.14 (0.769)   |
| 24 (610)                          | 14.70 (0.416)  | 26.41 (0.748)   |
| 23 (584)                          | 14.70 (0.416)  | 25.68 (0.727)   |
| 22 (559)                          | 14.70 (0.416)  | 24.95 (0.707)   |
| 21 (533)                          | 14.64 (0.415)  | 24.18 (0.685)   |
| 20 (508)                          | 14.49 (0.410)  | 23.36 (0.661)   |
| 19 (483)                          | 14.22 (0.403)  | 22.47 (0.636)   |
| 18 (457)                          | 13.68 (0.387)  | 21.41 (0.606)   |
| 17 (432)                          | 12.99 (0.368)  | 20.25 (0.573)   |
| 16 (406)                          | 12.17 (0.345)  | 19.03 (0.539)   |
| 15 (381)                          | 11.25 (0.319)  | 17.74 (0.502)   |
| 14 (356)                          | 10.23 (0.290)  | 16.40 (0.464)   |
| 13 (330)                          | 9.15 (0.260)   | 15.01 (0.425)   |
| 12 (305)                          | 7.99 (0.226)   | 13.59 (0.385)   |
| 11 (279)                          | 6.78 (0.192)   | 12.13 (0.343)   |
| 10 (254)                          | 5.51 (0.156)   | 10.63 (0.301)   |
| 9 (229)                           | 4.19 (0.119)   | 9.11 (0.258)  |
| 8 (203)                           | 2.83 (0.080)   | 7.56 (0.214)  |
| 7 (178)                           | 1.43 (0.041)   | 5.98 (0.169)  |
| 6 (152)                           | 0 (0)  | 4.39 (0.124)  |
| 5 (127)                           | 0 (0)  | 3.66 (0.104)  |
| 4 (102)                           | 0 (0)  | 2.93 (0.083)  |
| 3 (76)                            | 0 (0)  | 2.19 (0.062)  |
| 2 (51)                            | 0 (0)  | 1.46 (0.041)  |
| 1 (25)                            | 0 (0)  | 0.73 (0.021)  |

Stone Cover

Stone Foundation

**Note:** Add 0.73 ft<sup>3</sup> (0.021 m<sup>3</sup>) of storage for each additional inch (25 mm) of stone foundation.

**Storage Volume Per Chamber**

| ft <sup>3</sup> (m <sup>3</sup> ) | Bare Chamber Storage ft <sup>3</sup> (m <sup>3</sup> ) | Chamber and Stone Foundation Depth in. (mm) |             |             |
|-----------------------------------|--|---|-------------|-------------|
|                                   |  | 6 (150)                                     | 12 (300)    | 18 (450)    |
| SC-310-3                          | 14.7 (0.42)  | 29.3 (0.83)                                 | 33.7 (0.95) | 38.1 (1.08) |

**Note:** Assumes 6" (150 mm) of stone above chambers, 3" (76 mm) row spacing and 40% stone porosity.

**Amount of Stone Per Chamber**

| TONS (yds <sup>3</sup> ) | Stone Foundation Depth |           |           |
|--------------------------|------------------------|-----------|-----------|
|                          | 6                      | 12        | 16        |
| SC-310-3                 | 1.9 (1.4)              | 2.5 (1.8) | 3.1 (2.2) |

| KILOGRAMS (m <sup>3</sup> ) | Stone Foundation Depth |             |             |
|-----------------------------|------------------------|-------------|-------------|
|                             | 150 mm                 | 300 mm      | 450 mm      |
| SC-310-3                    | 1,724 (1.0)            | 2,268 (1.3) | 2,812 (1.7) |

**Note:** Assumes 6" (150 mm) of stone above and and 3" (76 mm) row spacing.

**Volume Excavation Per Chamber**

| yd <sup>3</sup> (m <sup>3</sup> ) | Stone Foundation Depth |           |           |
|-----------------------------------|------------------------|-----------|-----------|
|                                   | 6 (150)                | 12 (300)  | 18 (450)  |
| SC-310-3                          | 2.6 (2.0)              | 3.0 (2.0) | 3.4 (2.6) |

**Note:** Assumes 3" (76 mm) of row separation and 6" (150 mm) of stone above the chambers and 16" (400 mm) of cover. The volume of excavation will vary as depth of cover increases



# SC-740 Chamber

Designed to meet the most stringent industry performance standards for superior structural integrity while providing designers with a cost-effective method to save valuable land and protect water resources. The StormTech system is designed primarily to be used under parking lots, thus maximizing land usage for private (commercial) and public applications. StormTech chambers can also be used in conjunction with Green Infrastructure, thus enhancing the performance and extending the service life of these practices.

## StormTech SC-740 Chamber (not to scale)

### Nominal Specifications

|                         |   |
|-------------------------|---|
| Size (Lx W x H)         | 85.4" x 51.0" x 30.0"<br>(2,170 x 1,295 x 762 mm) |
| Chamber Storage         | 45.9 ft <sup>3</sup> (1.30 m <sup>3</sup> )       |
| Min. Installed Storage* | 74.9 ft <sup>3</sup> (2.12 m <sup>3</sup> )       |
| Weight                  | 74.0 lbs (33.6 kg)                                |

\*Assumes 6" (150 mm) stone above, below and between chambers and 40% stone porosity.

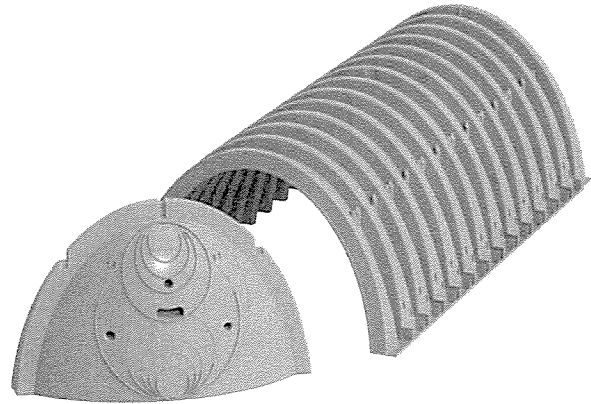

## Shipping

30 chambers/pallet

60 end caps/pallet

12 pallets/truck

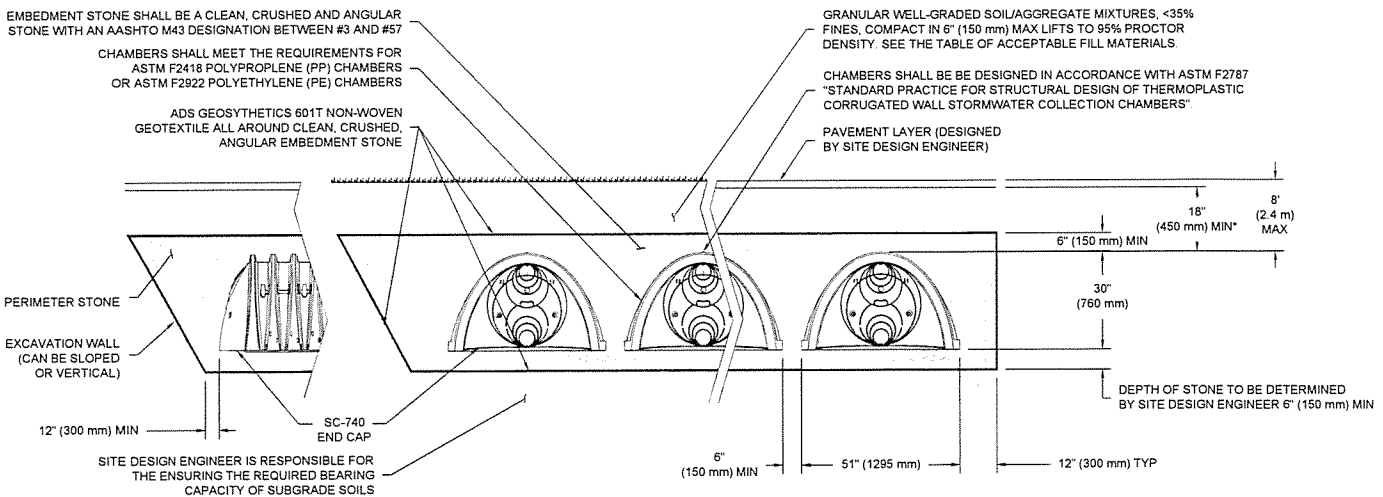
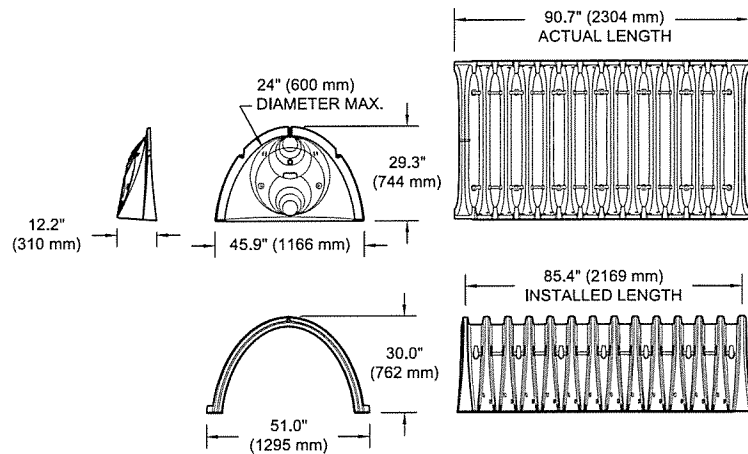

\*MINIMUM COVER TO BOTTOM OF FLEXIBLE PAVEMENT. FOR UNPAVED INSTALLATIONS WHERE RUTTING FROM VEHICLES MAY OCCUR, INCREASE COVER TO 24" (600 mm)

The installed chamber system shall provide the load factors specified in the aashto lrfd bridge design specifications section 12.12 for earth and live loads, with consideration for impact and multiple vehicle presences.

**SC-740 Cumulative Storage Volumes per chamber**  
Assumes 40% Stone Porosity. Calculations are Based Upon a 6" (150 mm) Stone Base Under Chambers.

| Depth of Water in System in. (mm) | Cumulative Chamber Storage ft <sup>3</sup> (m <sup>3</sup> ) | Total System Cumulative Storage ft <sup>3</sup> (m <sup>3</sup> ) |
|-----------------------------------|--|---|
| 42 (1067)                         | 45.90 (1.300)  | 74.90 (2.121)   |
| 41 (1041)                         | 45.90 (1.300)  | 73.77 (2.089)   |
| 40 (1016)                         | 45.90 (1.300)  | 72.64 (2.057)   |
| 39 (991)                          | 45.90 (1.300)  | 71.52 (2.025)   |
| 38 (965)                          | 45.90 (1.300)  | 70.39 (1.993)   |
| 37 (940)                          | 45.90 (1.300)  | 69.26 (1.961)   |
| 36 (914)                          | 45.90 (1.300)  | 68.14 (1.929)   |
| 35 (889)                          | 45.85 (1.298)  | 66.98 (1.897)   |
| 34 (864)                          | 45.69 (1.294)  | 65.75 (1.862)   |
| 33 (838)                          | 45.41 (1.286)  | 64.46 (1.825)   |
| 32 (813)                          | 44.81 (1.269)  | 62.97 (1.783)   |
| 31 (787)                          | 44.01 (1.246)  | 61.36 (1.737)   |
| 30 (762)                          | 43.06 (1.219)  | 59.66 (1.689)   |
| 29 (737)                          | 41.98 (1.189)  | 57.89 (1.639)   |
| 28 (711)                          | 40.80 (1.155)  | 56.05 (1.587)   |
| 27 (686)                          | 39.54 (1.120)  | 54.17 (1.534)   |
| 26 (660)                          | 38.18 (1.081)  | 52.23 (1.479)   |
| 25 (635)                          | 36.74 (1.040)  | 50.23 (1.422)   |
| 24 (610)                          | 35.22 (0.977)  | 48.19 (1.365)   |
| 23 (584)                          | 33.64 (0.953)  | 46.11 (1.306)   |
| 22 (559)                          | 31.99 (0.906)  | 44.00 (1.246)   |
| 21 (533)                          | 30.29 (0.858)  | 41.85 (1.185)   |
| 20 (508)                          | 28.54 (0.808)  | 39.67 (1.123)   |
| 19 (483)                          | 26.74 (0.757)  | 37.47 (1.061)   |
| 18 (457)                          | 24.89 (0.705)  | 35.23 (0.997)   |
| 17 (432)                          | 23.00 (0.651)  | 32.96 (0.939)   |
| 16 (406)                          | 21.06 (0.596)  | 30.68 (0.869)   |
| 15 (381)                          | 19.09 (0.541)  | 28.36 (0.803)   |
| 14 (356)                          | 17.08 (0.484)  | 26.03 (0.737)   |
| 13 (330)                          | 15.04 (0.426)  | 23.68 (0.670)   |
| 12 (305)                          | 12.97 (0.367)  | 21.31 (0.608)   |
| 11 (279)                          | 10.87 (0.309)  | 18.92 (0.535)   |
| 10 (254)                          | 8.74 (0.247)   | 16.51 (0.468)   |
| 9 (229)                           | 6.58 (0.186)   | 14.09 (0.399)   |
| 8 (203)                           | 4.41 (0.125)   | 11.66 (0.330)   |
| 7 (178)                           | 2.21 (0.063)   | 9.21 (0.264)  |
| 6 (152)                           | 0 (0)  | 6.76 (0.191)  |
| 5 (127)                           | 0 (0)  | 5.63 (0.160)  |
| 4 (102)                           | 0 (0)  | 4.51 (0.128)  |
| 3 (76)                            | 0 (0)  | 3.38 (0.096)  |
| 2 (51)                            | 0 (0)  | 2.25 (0.064)  |
| 1 (25)                            | 0 (0)  | 1.13 (0.032)  |

Stone Cover

Stone Foundation

**Note:** Add 1.13 ft<sup>3</sup> (0.032 m<sup>3</sup>) of storage for each additional inch (25 mm) of stone foundation.

**Storage Volume Per Chamber**

| ft <sup>3</sup> (m <sup>3</sup> ) | Bare Chamber Storage ft <sup>3</sup> (m <sup>3</sup> ) | Chamber and Stone Foundation Depth in. (mm) |            |            |
|-----------------------------------|--|---|------------|------------|
|                                   |  | 6 (150)                                     | 12 (300)   | 18 (450)   |
| SC-740                            | 45.9 (1.3)   | 74.9 (2.1)                                  | 81.7 (2.3) | 88.4 (2.5) |

**Note:** Assumes 6" (150 mm) stone above chambers, 6" (150 mm) row spacing and 40% stone porosity.

**Amount of Stone Per Chamber**

| TONS (yds <sup>3</sup> ) | Stone Foundation Depth |           |           |
|--------------------------|------------------------|-----------|-----------|
|                          | 6                      | 12        | 16        |
| SC-740                   | 3.8 (2.8)              | 4.6 (3.3) | 5.5 (3.9) |

| KILOGRAMS (m <sup>3</sup> ) | Stone Foundation Depth |             |             |
|-----------------------------|------------------------|-------------|-------------|
|                             | 150 mm                 | 300 mm      | 450 mm      |
| SC-740                      | 3,450 (2.1)            | 4,170 (2.5) | 4,490 (3.0) |

**Note:** Assumes 6" (150 mm) of stone above and between chambers.

**Volume Excavation Per Chamber**

| yd <sup>3</sup> (m <sup>3</sup> ) | Stone Foundation Depth |           |           |
|-----------------------------------|------------------------|-----------|-----------|
|                                   | 6 (150)                | 12 (300)  | 18 (450)  |
| SC-740                            | 5.5 (4.2)              | 6.2 (4.7) | 6.8 (5.2) |

**Note:** Assumes 6" (150 mm) of row separation and 18" (450 mm) of cover. The volume of excavation will vary as depth of cover increases.

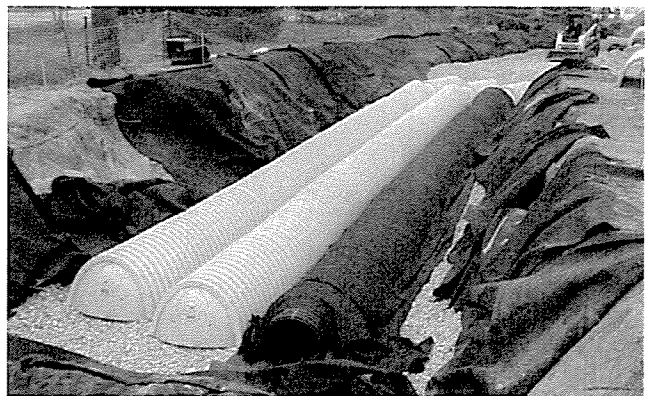

# DC-780 Chamber

Designed to meet the most stringent industry performance standards for superior structural integrity while providing designers with a cost-effective method to save valuable land and protect water resources. The StormTech system is designed primarily to be used under parking lots, thus maximizing land usage for private (commercial) and public applications. StormTech chambers can also be used in conjunction with Green Infrastructure, thus enhancing the performance and extending the service life of these practices.

- 12' (3.6 m) Deep Cover Applications
- Designed in accordance with ASTM F2787 and produced to meet the ASTM 2418 product standard.
- AASHTO safety factors provided for AASHTO Design Truck (H20 and deep cover conditions.)

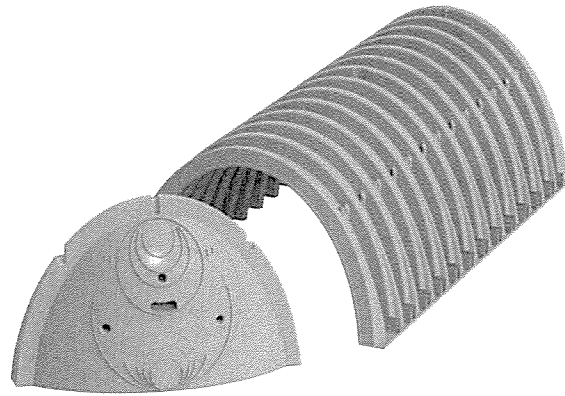

## DC-780 Chamber (not to scale)

Nominal Specifications

|                         |   |
|-------------------------|---|
| Size (Lx W x H)         | 85.4" x 51.0" x 30.0"<br>(2169 x 1295 x 762 mm) |
| Chamber Storage         | 46.2 ft <sup>3</sup> (1.30 m <sup>3</sup> )     |
| Min. Installed Storage* | 78.4 ft <sup>3</sup> (2.2 m <sup>3</sup> )      |

\*Assumes 9 (230 mm) stone below, 6 (150 mm) stone above, 6 (150 mm) row spacing and 40% stone porosity.

## Shipping

- 24 chambers/pallet
- 60 end caps/pallet
- 12 pallets/truck

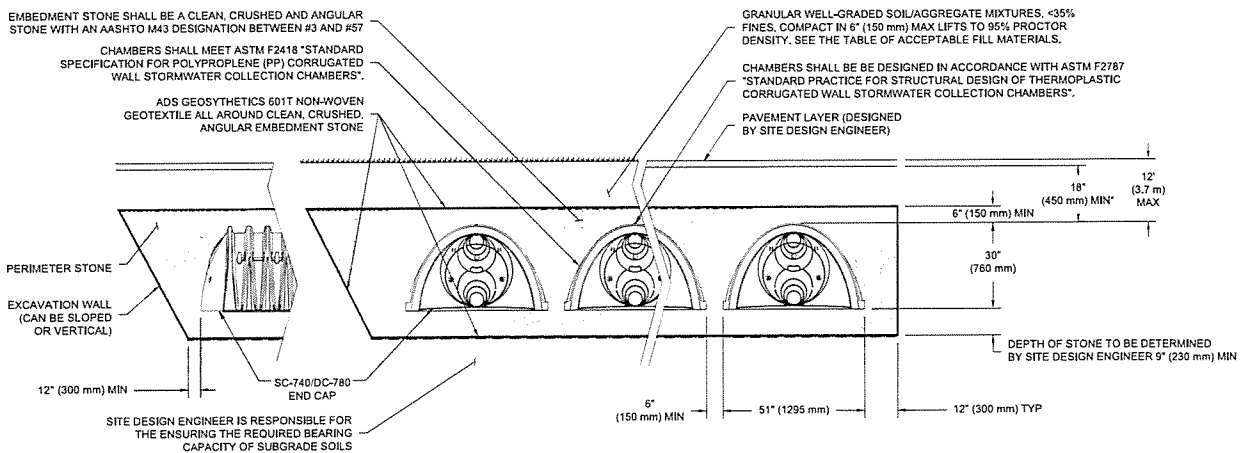
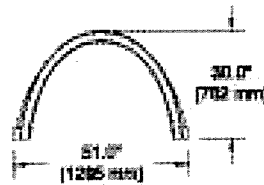
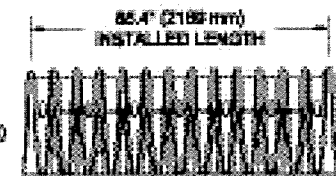
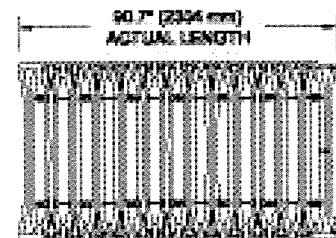

\*MINIMUM COVER TO BOTTOM OF FLEXIBLE PAVEMENT. FOR UNPAVED INSTALLATIONS WHERE RUTTING FROM VEHICLES MAY OCCUR, INCREASE COVER TO 24" (600 mm).

The installed chamber system shall provide the load factors specified in the aashto lfrd bridge design specifications section 12.12 for earth and live loads, with consideration for impact and multiple vehicle presences.

### DC-780 Cumulative Storage Volumes Per Chamber

Assumes 40% Stone Porosity. Calculations are Based Upon a 9" (230 mm) Stone Base Under Chambers.

| Depth of Water in System in. (mm) | Cumulative Chamber Storage ft <sup>3</sup> (m <sup>3</sup> ) | Total System Cumulative Storage ft <sup>3</sup> (m <sup>3</sup> ) |
|-----------------------------------|--|---|
| 45 (1,143)                        | 46.27 (1.310)  | 78.47 (2.222)   |
| 44 (1,118)                        | 46.27 (1.310)  | 77.34 (2.190)   |
| 43 (1,092)                        | 46.27 (1.310)  | 76.21 (2.158)   |
| 42 (1,067)                        | 46.27 (1.310)  | 75.09 (2.126)   |
| 41 (1,041)                        | 46.27 (1.310)  | 73.96 (2.094)   |
| 40 (1,016)                        | 46.27 (1.310)  | 72.83 (2.062)   |
| 39 (991)                          | 46.27 (1.310)  | 71.71 (2.030)   |
| 38 (965)                          | 46.21 (1.309)  | 70.54 (1.998)   |
| 37 (940)                          | 46.04 (1.304)  | 69.32 (1.963)   |
| 36 (914)                          | 45.76 (1.296)  | 68.02 (1.926)   |
| 35 (889)                          | 45.15 (1.278)  | 66.53 (1.884)   |
| 34 (864)                          | 44.34 (1.255)  | 64.91 (1.838)   |
| 33 (838)                          | 43.38 (1.228)  | 63.21 (1.790)   |
| 32 (813)                          | 42.29 (1.198)  | 61.43 (1.740)   |
| 31 (787)                          | 41.11 (1.164)  | 59.59 (1.688)   |
| 30 (762)                          | 39.83 (1.128)  | 57.70 (1.634)   |
| 29 (737)                          | 38.47 (1.089)  | 55.76 (1.579)   |
| 28 (711)                          | 37.01 (1.048)  | 53.76 (1.522)   |
| 27 (686)                          | 35.49 (1.005)  | 51.72 (1.464)   |
| 26 (660)                          | 33.90 (0.960)  | 49.63 (1.405)   |
| 25 (635)                          | 32.24 (0.913)  | 47.52 (1.346)   |
| 24 (610)                          | 30.54 (0.865)  | 45.36 (1.285)   |
| 23 (584)                          | 28.77 (0.815)  | 43.18 (1.223)   |
| 22 (559)                          | 26.96 (0.763)  | 40.97 (1.160)   |
| 21 (533)                          | 25.10 (0.711)  | 38.72 (1.096)   |
| 20 (508)                          | 23.19 (0.657)  | 36.45 (1.032)   |
| 19 (483)                          | 21.25 (0.602)  | 34.16 (0.967)   |
| 18 (457)                          | 19.26 (0.545)  | 31.84 (0.902)   |
| 17 (432)                          | 17.24 (0.488)  | 29.50 (0.835)   |
| 16 (406)                          | 15.19 (0.430)  | 27.14 (0.769)   |
| 15 (381)                          | 13.10 (0.371)  | 24.76 (0.701)   |
| 14 (356)                          | 10.98 (0.311)  | 22.36 (0.633)   |
| 13 (330)                          | 8.83 (0.250)   | 19.95 (0.565)   |
| 12 (305)                          | 6.66 (0.189)   | 17.52 (0.496)   |
| 11 (279)                          | 4.46 (0.126)   | 15.07 (0.427)   |
| 10 (254)                          | 2.24 (0.064)   | 12.61 (0.357)   |
| 9 (229)                           | 0 (0)  | 10.14 (0.287)   |
| 8 (203)                           | 0 (0)  | 9.01 (0.255)  |
| 7 (178)                           | 0 (0)  | 7.89 (0.223)  |
| 6 (152)                           | 0 (0)  | 6.76 (0.191)  |
| 5 (127)                           | 0 (0)  | 5.63 (0.160)  |
| 4 (102)                           | 0 (0)  | 4.51 (0.128)  |
| 3 (76)                            | 0 (0)  | 3.38 (0.096)  |
| 2 (51)                            | 0 (0)  | 2.25 (0.064)  |
| 1 (25)                            | 0 (0)  | 1.13 (0.032)  |

↑  
Stone  
Cover  
↓

↑  
Stone  
Foundation  
↓

Note: Add 1.13 ft<sup>3</sup> (0.032 m<sup>3</sup>) of Storage for Each Additional Inch (25 mm) of Stone Foundation.

### Storage Volume Per Chamber

| ft <sup>3</sup> (m <sup>3</sup> ) | Bare Chamber Storage ft <sup>3</sup> (m <sup>3</sup> ) | Chamber and Stone Foundation Depth in. (mm) |            |            |
|-----------------------------------|--|---|------------|------------|
|                                   |  | 9 (230)                                     | 12 (300)   | 18 (450)   |
| DC-780                            | 46.2 (1.3)   | 78.4 (2.2)                                  | 81.8 (2.3) | 88.6 (2.5) |

Note: Assumes 40% porosity for the stone, the bare chamber volume, 6" (150 mm) of stone above, and 6" (150 mm) row spacing.

### Amount of Stone Per Chamber

| TONS (yds <sup>3</sup> ) | Stone Foundation Depth |           |           |
|--------------------------|------------------------|-----------|-----------|
|                          | 9"                     | 12"       | 18"       |
| DC-780                   | 4.2 (3.0)              | 4.7 (3.3) | 5.6 (3.9) |

| KILOGRAMS (m <sup>3</sup> ) | Stone Foundation Depth |             |             |
|-----------------------------|------------------------|-------------|-------------|
|                             | 230 mm                 | 300 mm      | 450 mm      |
| DC-780                      | 3,810 (2.3)            | 4,264 (2.5) | 5,080 (3.0) |

Note: Assumes 9 (150 mm) of stone above, and between chambers.

### Volume Excavation Per Chamber

| yd <sup>3</sup> (m <sup>3</sup> ) | Stone Foundation Depth in. (mm) |           |           |
|-----------------------------------|---------------------------------|-----------|-----------|
|                                   | 9 (230)                         | 12 (300)  | 18 (450)  |
| DC-780                            | 5.9 (4.5)                       | 6.3 (4.8) | 6.9 (5.3) |

Note: Assumes 6" (150 mm) separation between chamber rows and 18" (450 mm) of cover. The volume of excavation will vary as depth of cover increases.

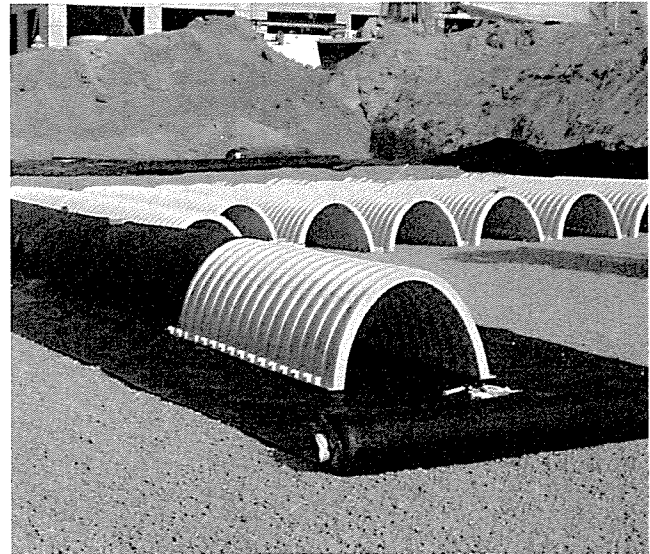

## 2.0 Product Information

### 2.5 StormTech Chambers

StormTech chamber systems have unique features to improve site optimization and reduce product waste. The SC-160LP, SC-310, SC-740, and DC-780 chambers can be cut at the job site in approximately 6.5 (165 mm) increments to shorten a chamber's length. Designing and constructing chamber rows around site obstacles is easily accomplished by including specific cutting instructions or a well placed cut to fit note on the design plans. The last chamber of a row can be cut in any of its corrugation's valleys. An end cap placed into the trimmed corrugation's crest completes the row. The trimmed-off piece of a StormTech chamber may then be used to start the next row. See **Figure 4**.

To assist the contractor, StormTech chambers are molded with simple assembly instructions and arrows that indicate the direction in which to build rows. Rows are formed by overlapping the next chamber's Start End corrugation with the previously laid chamber's end corrugation. Two people can safely and efficiently form rows of chambers without complicated connectors, special tools or heavy equipment.

*Product Specifications: 2.2, 2.4, 2.5, 2.9 and 3.2.*

### 2.6 StormTech End Caps

The StormTech end cap has features which make the chamber system simple to design, easy to build and more versatile than other products. StormTech end caps can be easily secured within any corrugation's crest. A molded-in handle makes attaching the end cap a one-person operation. Tools or fasteners are not required.

StormTech end caps are required at each end of a chamber row to prevent stone intrusion (two per row). The SC-740 and DC-780 end caps will accept up to a 24 (600 mm) HDPE inlet pipe. The SC-310 end cap will accept up to a 12 (300 mm) HDPE inlet pipe. The SC-160LP will accept either a 6 or 8 (150 mm or 200 mm) HDPE inlet Pipe. See **Figure 5**.

*Product Specifications: 3.1, 3.2, 3.3 and 3.4*

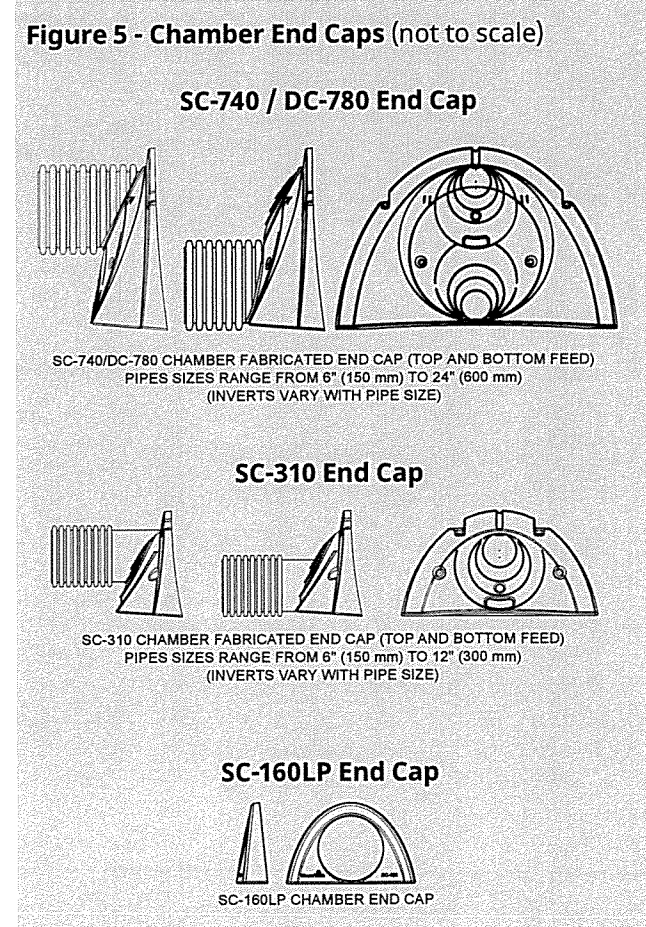
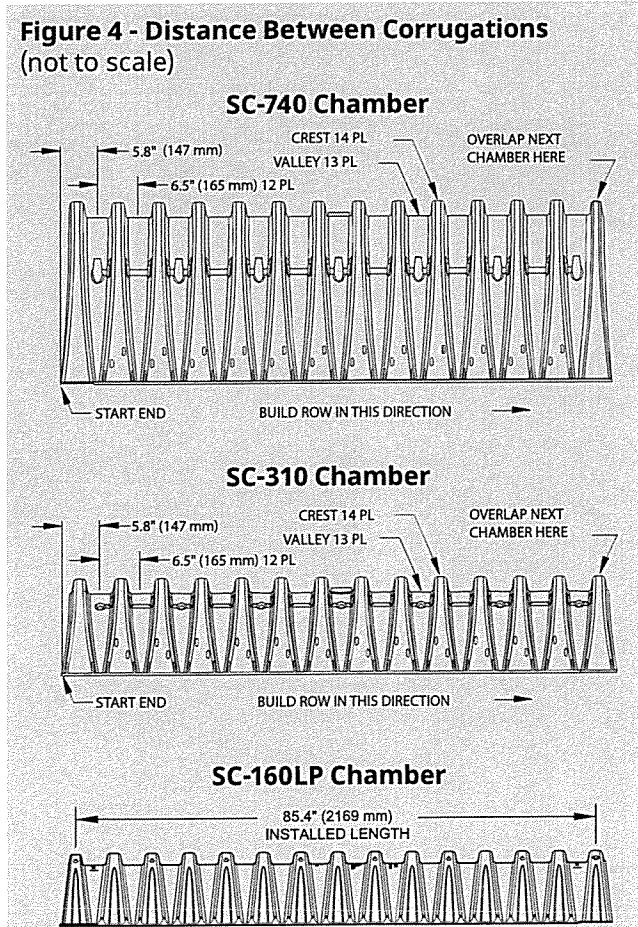
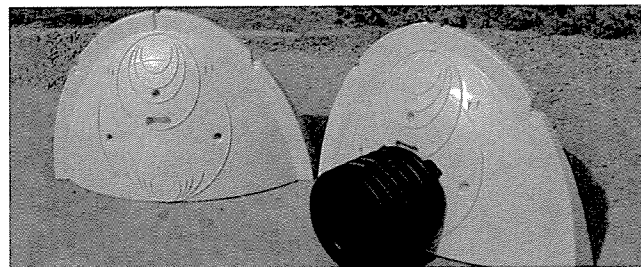

## 3.0 Structural Capabilities

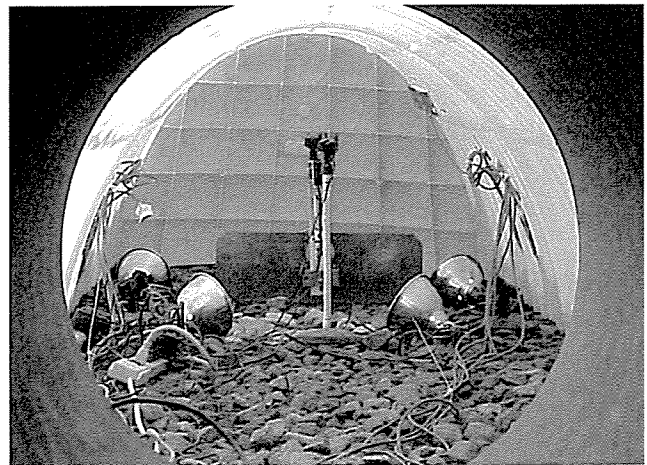

### 3.1 Structural Design Approach

When installed per StormTech's minimum requirements, StormTech products are designed to exceed American Association of State Highway and Transportation Officials (AASHTO) LRFD recommended design factors for Earth loads and Vehicular live loads. AASHTO Vehicular live loads (previously HS-20) consist of two heavy axle configurations, that of a single 32 (142 kN) kip axle and that of tandem 25 (111 kN) kip axles. Factors for impact and multiple presences of vehicles ensure a conservative design where structural adequacy is assumed for a wide range of street legal vehicle weights and axle configurations.

Computer models of the chambers under shallow and deep conditions were developed. Utilizing design forces from computer models, chamber sections were evaluated using AASHTO procedures that consider thrust and moment, and check for local buckling capacity. The procedures also considered the time-dependent strength and stiffness properties of polypropylene and polyethylene. These procedures were developed in a research study conducted by the National Cooperative Highway Research Program (NCHRP) for AASHTO, and published as NCHRP Report 438 Recommended LRFD Specifications for Plastic Pipe and Culverts. *Product Specifications: 2.12.*

StormTech does not recommend installing StormTech products underneath buildings or parking garages. When specifying the StormTech products in close proximity to buildings, it is important to ensure that the StormTech products are not receiving any loads from these structures that may jeopardize the long term performance of the chambers.

### 3.2 Full Scale Testing

After developing the StormTech chamber designs, the chambers were subjected to rigorous full-scale testing. The test programs verified the predicted safety factors of the designs by subjecting the chambers to more severe load conditions than anticipated during service life. Capacity under live loads and deep fill was investigated by conducting tests with a range of cover depths. Monitoring of long term deep fill installations has been done to validate the long term performance of the StormTech products.

### 3.3 Independent Expert Analysis

StormTech worked closely with the consulting firm Simpson Gumpertz & Heger Inc. (SGH) to develop and evaluate the SC-160LP, SC-310, SC-740 and DC-780 chamber designs. SGH has world-renowned expertise in the design of buried drainage structures. The firm was the principal investigator for the NCHRP research program that developed the structural analysis and design methods adopted by AASHTO for thermoplastic culverts. SGH conducted design calculations and computer simulations of chamber performance under various installation and live load conditions. They worked with StormTech to design the full-scale test programs to verify the structural capacity of the chambers. SGH also observed all full-scale tests and inspected the chambers after completion of the tests. SGH continues to be StormTech's structural consultant.



## 3.0 Structural Capabilities

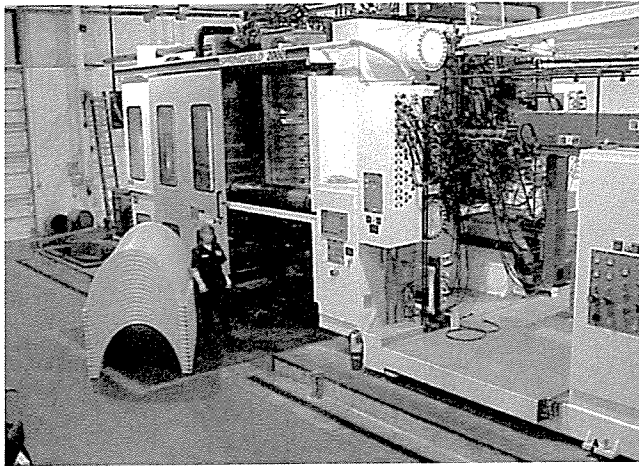

### 3.4 Injection Molding

To comply with both the structural and design requirements of AASHTO's LRFD specifications and ASTM F2787 as well as the product requirements of ASTM F2418 or ASTM F2922, StormTech uses proprietary injection molding equipment to manufacture the chambers and end caps.

In addition to meeting structural goals, injection molding allows StormTech to design added features and advantages into StormTech's parts including:

- Precise control of wall thickness throughout parts
- Precise fit of joints and end caps
- Molded-in inspection port fitting
- Molded-in handles on end caps
- Molded-in pipe guides with blade starter slots
- Repeatability for Quality Control (See Section 3.6)

*Product Specifications: 2.1, 3.1 and 3.3*

### 3.5 Polypropylene and Polyethylene

StormTech chambers are injection molded from polypropylene and polyethylene. Polypropylene and polyethylene chambers are inherently resistant to chemicals typically found in stormwater run-off. StormTech chambers maintain a greater portion of their structural stiffness through higher installation and service temperatures.

StormTech polypropylene and polyethylene are virgin materials specially designed to achieve a high 75-year creep modulus that is necessary to provide a sound long-term structural design. Since the modulus remains high well beyond the 75-year value, StormTech chambers can exhibit a service life in excess of 75 years.

### 3.6 Quality Control

StormTech chambers are manufactured under tight quality control programs. Materials are routinely tested in an environmentally controlled lab that is verified every six months via the external ASTM Proficiency Testing Program. The chamber material properties are measured and controlled with procedures following ISO 9001:2000 requirements.

Statistical Process Control (SPC) techniques are applied during manufacturing. Established upper and lower control limits are maintained on key manufacturing parameters to maintain consistent product.

*Product Specifications: 2.13 and 3.6*

# 4.0 Foundation for Chambers

## 4.1 Foundation Requirements

StormTech chamber systems and embedment stone may be installed in various native soil types. The subgrade bearing capacity and chamber cover height determine the required depth of clean, crushed, angular stone for the chamber foundation. The chamber foundation is the clean, crushed, angular stone placed between the subgrade soils and the feet of the chamber.

As cover height increases (top of chamber to top of finished grade) the chambers foundation requirements increase. Foundation strength is the product of the subgrade soils bearing capacity and the depth of clean, crushed, angular stone below the chamber foot. **Table 1** for the SC-160LP, **Table 2** for the SC-740 and SC-310, **Table 3** for the SC-310-3, and **Table 4** for the DC-780 specify the required minimum foundation depth for varying cover heights and subgrade bearing capacities. For additional guidance on foundation stone design please see our Technical Note 6.22 - StormTech Subgrade Performance.

## 4.2 WEAKER SOILS

For sub-grade soils with allowable bearing capacity less than 2000 pounds per square foot [(2.0 ksf) (96 kPa)], a geotechnical engineer should evaluate the specific conditions. These soils are often highly variable, may contain organic materials and could be

more sensitive to moisture. A geotechnical engineer's recommendations may include increasing the stone foundation, improving the bearing capacity of the sub-grade soils through compaction, replacement, or other remedial measures including the use of geogrids. The use of a thermoplastic liner may also be considered for systems installed in subgrade soils that are highly affected by moisture. The project engineer is responsible for ensuring overall site settlement is within acceptable limits. A geotechnical engineer should always review installation of StormTech chambers on organic soils.

## 4.3 CHAMBER SPACING OPTION

No spacing is required between the SC-160LP chambers. StormTech requires a minimum of 6 (150 mm) clear spacing between the feet of chambers rows for the SC-310, SC-740 and DC-780 chambers. However, increasing the spacing between chamber rows may allow the application of StormTech chambers with either less foundation stone or with weaker subgrade soils. This may be a good option where a vertical restriction on site prevents the use of a deeper foundation. Contact StormTech's Technical Service Department for more information on this option. In all cases, StormTech recommends consulting a geotechnical engineer for subgrade soils with a bearing capacity less than 2.0 ksf (96 kPa).

**Table 1 - SC-160LP Bearing Capacity Table**  
(Assumes no spacing) Minimum Required Foundation Depth in Inches (mm)

| Cover Hgt.<br>ft. (m)        | Minimum Bearing Resistance for Service Loads ksf (kPa) |              |              |              |              |              |              |              |              |              |              |              |              |              |              |              |              |              |             |
|------------------------------|--|--------------|--------------|--------------|--------------|--------------|--------------|--------------|--------------|--------------|--------------|--------------|--------------|--------------|--------------|--------------|--------------|--------------|-------------|
|                              | 4.4-3.8<br>(211 to 182)                                | 3.7<br>(177) | 3.6<br>(172) | 3.5<br>(168) | 3.4<br>(163) | 3.3<br>(158) | 3.2<br>(153) | 3.1<br>(148) | 3.0<br>(144) | 2.9<br>(139) | 2.8<br>(134) | 2.7<br>(129) | 2.6<br>(124) | 2.5<br>(120) | 2.4<br>(115) | 2.3<br>(110) | 2.2<br>(105) | 2.1<br>(101) | 2.0<br>(95) |
| 1.0<br>(0.31)                | 3<br>(75)  | 3<br>(75)    | 6<br>(150)   | 6<br>(150)   | 6<br>(150)   | 6<br>(150)   | 6<br>(150)   | 6<br>(150)   | 6<br>(150)   | 6<br>(150)   | 9<br>(230)   | 9<br>(230)   | 9<br>(230)   | 9<br>(230)   | 9<br>(230)   | 12<br>(300)  | 12<br>(300)  | 12<br>(300)  | 12<br>(300) |
| 1.2<br>(0.46)                | 3<br>(75)  | 3<br>(75)    | 3<br>(75)    | 6<br>(150)   | 6<br>(150)   | 6<br>(150)   | 6<br>(150)   | 6<br>(150)   | 6<br>(150)   | 6<br>(150)   | 6<br>(150)   | 9<br>(230)   | 9<br>(230)   | 9<br>(230)   | 9<br>(230)   | 9<br>(230)   | 9<br>(230)   | 12<br>(300)  | 12<br>(300) |
| 1.5<br>(0.46)                | 3<br>(75)  | 3<br>(75)    | 3<br>(75)    | 3<br>(75)    | 3<br>(75)    | 6<br>(150)   | 6<br>(150)   | 6<br>(150)   | 6<br>(150)   | 6<br>(150)   | 6<br>(150)   | 9<br>(230)   | 9<br>(230)   | 9<br>(230)   | 9<br>(230)   | 9<br>(230)   | 9<br>(230)   | 12<br>(300)  | 12<br>(300) |
| 2.0<br>(0.61)                | 3<br>(75)  | 3<br>(75)    | 3<br>(75)    | 3<br>(75)    | 3<br>(75)    | 3<br>(75)    | 3<br>(75)    | 3<br>(75)    | 3<br>(75)    | 3<br>(75)    | 3<br>(75)    | 6<br>(150)   | 6<br>(150)   | 6<br>(150)   | 6<br>(150)   | 6<br>(150)   | 6<br>(150)   | 9<br>(230)   | 9<br>(230)  |
| 2.5<br>(0.76)                | 3<br>(75)  | 3<br>(75)    | 3<br>(75)    | 3<br>(75)    | 3<br>(75)    | 3<br>(75)    | 3<br>(75)    | 3<br>(75)    | 3<br>(75)    | 3<br>(75)    | 3<br>(75)    | 3<br>(75)    | 3<br>(75)    | 3<br>(75)    | 3<br>(75)    | 3<br>(75)    | 6<br>(150)   | 6<br>(150)   | 6<br>(150)  |
| 3.0<br>(0.91)                | 3<br>(75)  | 3<br>(75)    | 3<br>(75)    | 3<br>(75)    | 3<br>(75)    | 3<br>(75)    | 3<br>(75)    | 3<br>(75)    | 3<br>(75)    | 3<br>(75)    | 3<br>(75)    | 3<br>(75)    | 3<br>(75)    | 3<br>(75)    | 3<br>(75)    | 3<br>(75)    | 3<br>(75)    | 6<br>(150)   | 6<br>(150)  |
| 3.5 to 6.0<br>(1.07 to 1.86) | 3<br>(75)  | 3<br>(75)    | 3<br>(75)    | 3<br>(75)    | 3<br>(75)    | 3<br>(75)    | 3<br>(75)    | 3<br>(75)    | 3<br>(75)    | 3<br>(75)    | 3<br>(75)    | 3<br>(75)    | 3<br>(75)    | 3<br>(75)    | 3<br>(75)    | 3<br>(75)    | 3<br>(75)    | 3<br>(75)    | 3<br>(75)   |
| 6.5<br>(1.98)                | 3<br>(75)  | 3<br>(75)    | 3<br>(75)    | 3<br>(75)    | 3<br>(75)    | 3<br>(75)    | 3<br>(75)    | 3<br>(75)    | 3<br>(75)    | 3<br>(75)    | 3<br>(75)    | 3<br>(75)    | 3<br>(75)    | 3<br>(75)    | 3<br>(75)    | 3<br>(75)    | 3<br>(75)    | 3<br>(75)    | 6<br>(150)  |
| 7.0<br>(2.13)                | 3<br>(75)  | 3<br>(75)    | 3<br>(75)    | 3<br>(75)    | 3<br>(75)    | 3<br>(75)    | 3<br>(75)    | 3<br>(75)    | 3<br>(75)    | 3<br>(75)    | 3<br>(75)    | 3<br>(75)    | 3<br>(75)    | 3<br>(75)    | 3<br>(75)    | 3<br>(75)    | 3<br>(75)    | 3<br>(75)    | 6<br>(150)  |
| 7.5<br>(2.30)                | 3<br>(75)  | 3<br>(75)    | 3<br>(75)    | 3<br>(75)    | 3<br>(75)    | 3<br>(75)    | 3<br>(75)    | 3<br>(75)    | 3<br>(75)    | 3<br>(75)    | 3<br>(75)    | 3<br>(75)    | 3<br>(75)    | 3<br>(75)    | 3<br>(75)    | 3<br>(75)    | 3<br>(75)    | 6<br>(150)   | 6<br>(150)  |
| 8.0<br>(2.44)                | 3<br>(75)  | 3<br>(75)    | 3<br>(75)    | 3<br>(75)    | 3<br>(75)    | 3<br>(75)    | 3<br>(75)    | 3<br>(75)    | 3<br>(75)    | 3<br>(75)    | 3<br>(75)    | 3<br>(75)    | 3<br>(75)    | 3<br>(75)    | 3<br>(75)    | 3<br>(75)    | 6<br>(150)   | 6<br>(150)   | 6<br>(150)  |
| 8.5<br>(2.59)                | 3<br>(75)  | 3<br>(75)    | 3<br>(75)    | 3<br>(75)    | 3<br>(75)    | 3<br>(75)    | 3<br>(75)    | 3<br>(75)    | 3<br>(75)    | 3<br>(75)    | 3<br>(75)    | 3<br>(75)    | 3<br>(75)    | 3<br>(75)    | 3<br>(75)    | 6<br>(150)   | 6<br>(150)   | 6<br>(150)   | 6<br>(150)  |
| 9.0<br>(2.74)                | 3<br>(75)  | 3<br>(75)    | 3<br>(75)    | 3<br>(75)    | 3<br>(75)    | 3<br>(75)    | 3<br>(75)    | 3<br>(75)    | 3<br>(75)    | 3<br>(75)    | 3<br>(75)    | 3<br>(75)    | 3<br>(75)    | 3<br>(75)    | 6<br>(150)   | 6<br>(150)   | 6<br>(150)   | 6<br>(150)   | 9<br>(230)  |
| 9.5<br>(2.89)                | 3<br>(75)  | 3<br>(75)    | 3<br>(75)    | 3<br>(75)    | 3<br>(75)    | 3<br>(75)    | 3<br>(75)    | 3<br>(75)    | 3<br>(75)    | 3<br>(75)    | 3<br>(75)    | 3<br>(75)    | 3<br>(75)    | 3<br>(75)    | 6<br>(150)   | 6<br>(150)   | 6<br>(150)   | 6<br>(150)   | 9<br>(230)  |
| 10.0<br>(3.05)               | 3<br>(75)  | 3<br>(75)    | 3<br>(75)    | 3<br>(75)    | 3<br>(75)    | 3<br>(75)    | 3<br>(75)    | 3<br>(75)    | 3<br>(75)    | 3<br>(75)    | 3<br>(75)    | 3<br>(75)    | 6<br>(150)   | 6<br>(150)   | 6<br>(150)   | 6<br>(150)   | 9<br>(230)   | 9<br>(230)   | 9<br>(230)  |

**Note:** The design engineer is solely responsible for assessing the bearing resistance (allowable bearing capacity) of the subgrade soils and determining the depth of foundation stone. Subgrade bearing resistance should be assessed with consideration for the range of soil moisture conditions expected under a stormwater system.

# 4.0 Foundations for Chambers

**Table 2 - SC-310 Minimum Required Foundation Depth in inches (millimeters)**

| Cover Hgt. ft. (m) | Minimum Required Bearing Resistance for Service Loads ksf (kPa) |           |           |           |           |           |           |           |           |           |           |           |           |           |           |           |           |           |           |           |           |          |
|--------------------|---|-----------|-----------|-----------|-----------|-----------|-----------|-----------|-----------|-----------|-----------|-----------|-----------|-----------|-----------|-----------|-----------|-----------|-----------|-----------|-----------|----------|
|                    | 4.1 (196)   | 4.0 (192) | 3.9 (187) | 3.8 (182) | 3.7 (177) | 3.6 (172) | 3.5 (168) | 3.4 (163) | 3.3 (158) | 3.2 (153) | 3.1 (148) | 3.0 (144) | 2.9 (139) | 2.8 (134) | 2.7 (129) | 2.6 (124) | 2.5 (120) | 2.4 (115) | 2.3 (110) | 2.2 (105) | 2.1 (101) | 2.0 (96) |
| 1.5 (0.46)         | 6 (150)   | 6 (150)   | 6 (150)   | 6 (150)   | 6 (150)   | 6 (150)   | 6 (150)   | 6 (150)   | 6 (150)   | 6 (150)   | 6 (150)   | 6 (150)   | 9 (230)   | 9 (230)   | 9 (230)   | 9 (230)   | 9 (230)   | 9 (230)   | 12 (300)  | 12 (300)  | 12 (300)  | 12 (300) |
| 2.0 (0.61)         | 6 (150)   | 6 (150)   | 6 (150)   | 6 (150)   | 6 (150)   | 6 (150)   | 6 (150)   | 6 (150)   | 6 (150)   | 6 (150)   | 6 (150)   | 6 (150)   | 9 (150)   | 9 (230)   | 9 (230)   | 9 (230)   | 9 (230)   | 9 (230)   | 12 (300)  | 12 (300)  | 12 (300)  | 12 (300) |
| 2.5 (0.76)         | 6 (150)   | 6 (150)   | 6 (150)   | 6 (150)   | 6 (150)   | 6 (150)   | 6 (150)   | 6 (150)   | 6 (150)   | 6 (150)   | 6 (150)   | 6 (150)   | 6 (150)   | 6 (150)   | 6 (150)   | 9 (230)   | 9 (230)   | 9 (230)   | 9 (230)   | 12 (300)  | 12 (300)  | 12 (300) |
| 3.0 (0.91)         | 6 (150)   | 6 (150)   | 6 (150)   | 6 (150)   | 6 (150)   | 6 (150)   | 6 (150)   | 6 (150)   | 6 (150)   | 6 (150)   | 6 (150)   | 6 (150)   | 6 (150)   | 6 (150)   | 6 (150)   | 6 (150)   | 9 (230)   | 9 (230)   | 9 (230)   | 9 (230)   | 12 (300)  | 12 (300) |
| 3.5 (1.07)         | 6 (150)   | 6 (150)   | 6 (150)   | 6 (150)   | 6 (150)   | 6 (150)   | 6 (150)   | 6 (150)   | 6 (150)   | 6 (150)   | 6 (150)   | 6 (150)   | 6 (150)   | 6 (150)   | 6 (150)   | 6 (150)   | 9 (230)   | 9 (230)   | 9 (230)   | 9 (230)   | 9 (230)   | 9 (230)  |
| 4.0 (1.22)         | 6 (150)   | 6 (150)   | 6 (150)   | 6 (150)   | 6 (150)   | 6 (150)   | 6 (150)   | 6 (150)   | 6 (150)   | 6 (150)   | 6 (150)   | 6 (150)   | 6 (150)   | 6 (150)   | 6 (150)   | 6 (150)   | 6 (150)   | 6 (150)   | 9 (230)   | 9 (230)   | 9 (230)   | 9 (230)  |
| 4.5 (1.37)         | 6 (150)   | 6 (150)   | 6 (150)   | 6 (150)   | 6 (150)   | 6 (150)   | 6 (150)   | 6 (150)   | 6 (150)   | 6 (150)   | 6 (150)   | 6 (150)   | 6 (150)   | 6 (150)   | 6 (150)   | 6 (150)   | 6 (150)   | 6 (150)   | 9 (230)   | 9 (230)   | 9 (230)   | 9 (230)  |
| 5.0 (1.52)         | 6 (150)   | 6 (150)   | 6 (150)   | 6 (150)   | 6 (150)   | 6 (150)   | 6 (150)   | 6 (150)   | 6 (150)   | 6 (150)   | 6 (150)   | 6 (150)   | 6 (150)   | 6 (150)   | 6 (150)   | 6 (150)   | 6 (150)   | 6 (150)   | 9 (230)   | 9 (230)   | 9 (230)   | 9 (230)  |
| 5.5 (1.68)         | 6 (150)   | 6 (150)   | 6 (150)   | 6 (150)   | 6 (150)   | 6 (150)   | 6 (150)   | 6 (150)   | 6 (150)   | 6 (150)   | 6 (150)   | 6 (150)   | 6 (150)   | 6 (150)   | 6 (150)   | 6 (150)   | 6 (150)   | 6 (150)   | 9 (230)   | 9 (230)   | 9 (230)   | 12 (300) |
| 6.0 (1.83)         | 6 (150)   | 6 (150)   | 6 (150)   | 6 (150)   | 6 (150)   | 6 (150)   | 6 (150)   | 6 (150)   | 6 (150)   | 6 (150)   | 6 (150)   | 6 (150)   | 6 (150)   | 6 (150)   | 6 (150)   | 6 (150)   | 6 (150)   | 9 (230)   | 9 (230)   | 9 (230)   | 9 (230)   | 12 (300) |
| 6.5 (1.98)         | 6 (150)   | 6 (150)   | 6 (150)   | 6 (150)   | 6 (150)   | 6 (150)   | 6 (150)   | 6 (150)   | 6 (150)   | 6 (150)   | 6 (150)   | 6 (150)   | 6 (150)   | 6 (150)   | 6 (150)   | 6 (150)   | 6 (150)   | 9 (230)   | 9 (230)   | 9 (230)   | 9 (230)   | 12 (300) |
| 7.0 (2.13)         | 6 (150)   | 6 (150)   | 6 (150)   | 6 (150)   | 6 (150)   | 6 (150)   | 6 (150)   | 6 (150)   | 6 (150)   | 6 (150)   | 6 (150)   | 6 (150)   | 6 (150)   | 6 (150)   | 6 (150)   | 6 (150)   | 6 (150)   | 9 (230)   | 9 (230)   | 9 (230)   | 9 (230)   | 12 (300) |
| 7.5 (2.30)         | 6 (150)   | 6 (150)   | 6 (150)   | 6 (150)   | 6 (150)   | 6 (150)   | 6 (150)   | 6 (150)   | 6 (150)   | 6 (150)   | 6 (150)   | 6 (150)   | 6 (150)   | 6 (150)   | 6 (150)   | 6 (150)   | 6 (150)   | 9 (230)   | 9 (230)   | 9 (230)   | 9 (230)   | 12 (300) |
| 8.0 (2.44)         | 6 (150)   | 6 (150)   | 6 (150)   | 6 (150)   | 6 (150)   | 6 (150)   | 6 (150)   | 6 (150)   | 6 (150)   | 6 (150)   | 6 (150)   | 6 (150)   | 6 (150)   | 6 (150)   | 9 (230)   | 9 (230)   | 9 (230)   | 9 (230)   | 12 (300)  | 12 (300)  | 12 (300)  | 15 (375) |

**Note:** The design engineer is solely responsible for assessing the bearing resistance (allowable bearing capacity) of the subgrade soils and determining the depth of foundation stone. Subgrade bearing resistance should be assessed with consideration for the range of soil moisture conditions expected under a stormwater system.

**Table 3 - SC-740 Minimum Required Foundation Depth in inches (millimeters)**

| Cover Hgt. ft. (m) | Minimum Required Bearing Resistance for Service Loads ksf (kPa) |           |           |           |           |           |           |           |           |           |           |           |           |           |           |           |           |           |           |           |           |          |
|--------------------|---|-----------|-----------|-----------|-----------|-----------|-----------|-----------|-----------|-----------|-----------|-----------|-----------|-----------|-----------|-----------|-----------|-----------|-----------|-----------|-----------|----------|
|                    | 4.1 (196)   | 4.0 (192) | 3.9 (187) | 3.8 (182) | 3.7 (177) | 3.6 (172) | 3.5 (168) | 3.4 (163) | 3.3 (158) | 3.2 (153) | 3.1 (148) | 3.0 (144) | 2.9 (139) | 2.8 (134) | 2.7 (129) | 2.6 (124) | 2.5 (120) | 2.4 (115) | 2.3 (110) | 2.2 (105) | 2.1 (101) | 2.0 (96) |
| 1.5 (0.46)         | 6 (150)   | 6 (150)   | 6 (150)   | 6 (150)   | 6 (150)   | 6 (150)   | 6 (150)   | 6 (150)   | 6 (150)   | 6 (150)   | 6 (150)   | 9 (230)   | 9 (230)   | 9 (230)   | 9 (230)   | 9 (230)   | 9 (230)   | 12 (300)  | 12 (300)  | 12 (300)  | 15 (375)  | 15 (375) |
| 2.0 (0.61)         | 6 (150)   | 6 (150)   | 6 (150)   | 6 (150)   | 6 (150)   | 6 (150)   | 6 (150)   | 6 (150)   | 6 (150)   | 6 (150)   | 9 (230)   | 9 (230)   | 9 (230)   | 9 (230)   | 9 (230)   | 9 (230)   | 12 (300)  | 12 (300)  | 12 (300)  | 12 (300)  | 15 (375)  | 15 (375) |
| 2.5 (0.76)         | 6 (150)   | 6 (150)   | 6 (150)   | 6 (150)   | 6 (150)   | 6 (150)   | 6 (150)   | 6 (150)   | 6 (150)   | 9 (230)   | 9 (230)   | 9 (230)   | 9 (230)   | 9 (230)   | 9 (230)   | 12 (300)  | 12 (300)  | 12 (300)  | 12 (300)  | 15 (375)  | 15 (375)  | 15 (375) |
| 3.0 (0.91)         | 6 (150)   | 6 (150)   | 6 (150)   | 6 (150)   | 6 (150)   | 6 (150)   | 6 (150)   | 6 (150)   | 9 (230)   | 9 (230)   | 9 (230)   | 9 (230)   | 9 (230)   | 9 (230)   | 12 (300)  | 12 (300)  | 12 (300)  | 12 (300)  | 15 (375)  | 15 (375)  | 15 (375)  | 18 (450) |
| 3.5 (1.07)         | 6 (150)   | 6 (150)   | 6 (150)   | 6 (150)   | 6 (150)   | 6 (150)   | 6 (150)   | 9 (230)   | 9 (230)   | 9 (230)   | 9 (230)   | 9 (230)   | 9 (230)   | 12 (300)  | 12 (300)  | 12 (300)  | 12 (300)  | 15 (375)  | 15 (375)  | 15 (375)  | 18 (450)  | 18 (450) |
| 4.0 (1.22)         | 6 (150)   | 6 (150)   | 6 (150)   | 6 (150)   | 6 (150)   | 6 (150)   | 6 (150)   | 9 (230)   | 9 (230)   | 9 (230)   | 9 (230)   | 9 (230)   | 12 (300)  | 12 (300)  | 12 (300)  | 12 (300)  | 12 (300)  | 15 (375)  | 15 (375)  | 15 (375)  | 18 (450)  | 18 (450) |
| 4.5 (1.37)         | 6 (150)   | 6 (150)   | 6 (150)   | 6 (150)   | 6 (150)   | 6 (150)   | 6 (150)   | 9 (230)   | 9 (230)   | 9 (230)   | 9 (230)   | 9 (230)   | 12 (300)  | 12 (300)  | 12 (300)  | 12 (300)  | 12 (300)  | 15 (375)  | 15 (375)  | 15 (375)  | 18 (450)  | 18 (450) |
| 5.0 (1.52)         | 6 (150)   | 6 (150)   | 6 (150)   | 6 (150)   | 6 (150)   | 6 (150)   | 6 (150)   | 9 (230)   | 9 (230)   | 9 (230)   | 9 (230)   | 9 (230)   | 12 (300)  | 12 (300)  | 12 (300)  | 12 (300)  | 12 (300)  | 15 (375)  | 15 (375)  | 15 (375)  | 18 (450)  | 18 (450) |
| 5.5 (1.68)         | 6 (150)   | 6 (150)   | 6 (150)   | 6 (150)   | 6 (150)   | 6 (150)   | 9 (230)   | 9 (230)   | 9 (230)   | 9 (230)   | 9 (230)   | 12 (300)  | 12 (300)  | 12 (300)  | 12 (300)  | 12 (300)  | 15 (375)  | 15 (375)  | 15 (375)  | 18 (450)  | 18 (450)  | 18 (450) |
| 6.0 (1.83)         | 6 (150)   | 6 (150)   | 6 (150)   | 6 (150)   | 6 (150)   | 9 (230)   | 9 (230)   | 9 (230)   | 9 (230)   | 9 (230)   | 12 (300)  | 12 (300)  | 12 (300)  | 12 (300)  | 12 (300)  | 12 (300)  | 15 (375)  | 15 (375)  | 18 (450)  | 18 (450)  | 18 (450)  | 21 (525) |
| 6.5 (1.98)         | 6 (150)   | 6 (150)   | 6 (150)   | 6 (150)   | 9 (230)   | 9 (230)   | 9 (230)   | 9 (230)   | 9 (230)   | 12 (300)  | 12 (300)  | 12 (300)  | 12 (300)  | 12 (300)  | 12 (300)  | 15 (375)  | 15 (375)  | 18 (450)  | 18 (450)  | 18 (450)  | 18 (450)  | 21 (525) |
| 7.0 (2.13)         | 6 (150)   | 6 (150)   | 6 (150)   | 9 (230)   | 9 (230)   | 9 (230)   | 9 (230)   | 9 (230)   | 12 (300)  | 12 (300)  | 12 (300)  | 12 (300)  | 12 (300)  | 12 (300)  | 15 (375)  | 15 (375)  | 18 (450)  | 18 (450)  | 18 (450)  | 18 (450)  | 21 (525)  | 21 (525) |
| 7.5 (2.30)         | 6 (150)   | 6 (150)   | 9 (230)   | 9 (230)   | 9 (230)   | 9 (230)   | 9 (230)   | 12 (300)  | 12 (300)  | 12 (300)  | 12 (300)  | 12 (300)  | 12 (300)  | 15 (375)  | 15 (375)  | 15 (375)  | 18 (450)  | 18 (450)  | 18 (450)  | 21 (525)  | 21 (525)  | 21 (525) |
| 8.0 (2.44)         | 6 (150)   | 9 (230)   | 9 (230)   | 9 (230)   | 9 (230)   | 9 (230)   | 12 (300)  | 12 (300)  | 12 (300)  | 12 (300)  | 12 (300)  | 12 (300)  | 15 (375)  | 15 (375)  | 15 (375)  | 18 (450)  | 18 (450)  | 18 (450)  | 21 (525)  | 21 (525)  | 21 (525)  | 24 (600) |

**Note:** The design engineer is solely responsible for assessing the bearing resistance (allowable bearing capacity) of the subgrade soils and determining the depth of foundation stone. Subgrade bearing resistance should be assessed with consideration for the range of soil moisture conditions expected under a stormwater system.

# 4.0 Foundations for Chambers

**Table 4 - SC-310-3 Minimum Required Foundation Depth in inches (millimeters)**

| Cover Hgt. ft.<br>(m) | Minimum Required Bearing Resistance for Service Loads ksf (kPa) |              |              |              |              |              |              |              |              |              |             |
|-----------------------|---|--------------|--------------|--------------|--------------|--------------|--------------|--------------|--------------|--------------|-------------|
|                       | 3.0<br>(144)  | 2.9<br>(139) | 2.8<br>(134) | 2.7<br>(129) | 2.6<br>(124) | 2.5<br>(120) | 2.4<br>(115) | 2.3<br>(110) | 2.2<br>(105) | 2.1<br>(101) | 2.0<br>(96) |
| 1.5<br>(0.46)         | 9<br>(230)  | 9<br>(230)   | 9<br>(230)   | 9<br>(230)   | 12<br>(300)  | 12<br>(300)  | 12<br>(300)  | 12<br>(300)  | 12<br>(300)  | 15<br>(375)  | 15<br>(375) |
| 2.0<br>(0.61)         | 9<br>(230)  | 9<br>(230)   | 9<br>(230)   | 9<br>(230)   | 12<br>(300)  | 12<br>(300)  | 12<br>(300)  | 12<br>(300)  | 12<br>(300)  | 15<br>(375)  | 15<br>(375) |
| 2.5<br>(0.76)         | 6<br>(150)  | 9<br>(230)   | 9<br>(230)   | 9<br>(230)   | 9<br>(230)   | 9<br>(230)   | 9<br>(230)   | 12<br>(300)  | 12<br>(300)  | 12<br>(300)  | 12<br>(300) |
| 3.0<br>(0.91)         | 6<br>(150)  | 6<br>(150)   | 6<br>(150)   | 9<br>(230)   | 9<br>(230)   | 9<br>(230)   | 9<br>(230)   | 9<br>(230)   | 12<br>(300)  | 12<br>(300)  | 12<br>(300) |
| 3.5<br>(1.07)         | 6<br>(150)  | 6<br>(150)   | 6<br>(150)   | 6<br>(150)   | 9<br>(230)   | 9<br>(230)   | 9<br>(230)   | 9<br>(230)   | 9<br>(230)   | 12<br>(300)  | 12<br>(300) |
| 4.0<br>(1.22)         | 6<br>(150)  | 6<br>(150)   | 6<br>(150)   | 6<br>(150)   | 9<br>(230)   | 9<br>(230)   | 9<br>(230)   | 9<br>(230)   | 9<br>(230)   | 9<br>(230)   | 12<br>(300) |
| 4.5<br>(1.37)         | 6<br>(150)  | 6<br>(150)   | 6<br>(150)   | 6<br>(150)   | 6<br>(150)   | 9<br>(230)   | 9<br>(230)   | 9<br>(230)   | 9<br>(230)   | 9<br>(230)   | 12<br>(300) |
| 5.0<br>(1.52)         | 6<br>(150)  | 6<br>(150)   | 6<br>(150)   | 6<br>(150)   | 9<br>(230)   | 9<br>(230)   | 9<br>(230)   | 9<br>(230)   | 9<br>(230)   | 12<br>(300)  | 12<br>(300) |
| 5.5<br>(1.68)         | 6<br>(150)  | 6<br>(150)   | 6<br>(150)   | 6<br>(150)   | 9<br>(230)   | 9<br>(230)   | 9<br>(230)   | 9<br>(230)   | 9<br>(230)   | 12<br>(300)  | 12<br>(300) |
| 6.0<br>(1.83)         | 6<br>(150)  | 6<br>(150)   | 6<br>(150)   | 9<br>(230)   | 9<br>(230)   | 9<br>(230)   | 9<br>(230)   | 9<br>(230)   | 12<br>(300)  | 12<br>(300)  | 12<br>(300) |
| 6.5<br>(1.98)         | 6<br>(150)  | 6<br>(150)   | 6<br>(150)   | 9<br>(230)   | 9<br>(230)   | 9<br>(230)   | 9<br>(230)   | 9<br>(230)   | 12<br>(300)  | 12<br>(300)  | 12<br>(300) |
| 7.0<br>(2.13)         | 6<br>(150)  | 6<br>(150)   | 9<br>(230)   | 9<br>(230)   | 9<br>(230)   | 9<br>(230)   | 9<br>(230)   | 12<br>(300)  | 12<br>(300)  | 12<br>(300)  | 12<br>(300) |
| 7.5<br>(2.30)         | 6<br>(150)  | 9<br>(230)   | 9<br>(230)   | 9<br>(230)   | 9<br>(230)   | 9<br>(230)   | 12<br>(300)  | 12<br>(300)  | 12<br>(300)  | 12<br>(300)  | 15<br>(375) |
| 8.0<br>(2.44)         | 9<br>(230)  | 9<br>(230)   | 9<br>(230)   | 9<br>(230)   | 9<br>(230)   | 9<br>(230)   | 12<br>(300)  | 12<br>(300)  | 12<br>(300)  | 12<br>(300)  | 15<br>(375) |

**Note:** The design engineer is solely responsible for assessing the bearing resistance (allowable bearing capacity) of the subgrade soils and determining the depth of foundation stone. Subgrade bearing resistance should be assessed with consideration for the range of soil moisture conditions expected under a stormwater system.

**Table 5 - DC-780 Minimum Required Foundation Depth in inches (millimeters)**

| Cover Hgt. ft.<br>(m) | Minimum Required Bearing Resistance for Service Loads ksf (kPa) |              |              |              |              |              |              |              |              |              |              |              |              |              |              |              |              |              |              |              |              |             |
|-----------------------|---|--------------|--------------|--------------|--------------|--------------|--------------|--------------|--------------|--------------|--------------|--------------|--------------|--------------|--------------|--------------|--------------|--------------|--------------|--------------|--------------|-------------|
|                       | 4.1<br>(196)  | 4.0<br>(192) | 3.9<br>(187) | 3.8<br>(182) | 3.7<br>(177) | 3.6<br>(172) | 3.5<br>(168) | 3.4<br>(163) | 3.3<br>(158) | 3.2<br>(153) | 3.1<br>(148) | 3.0<br>(144) | 2.9<br>(139) | 2.8<br>(134) | 2.7<br>(129) | 2.6<br>(124) | 2.5<br>(120) | 2.4<br>(115) | 2.3<br>(110) | 2.2<br>(105) | 2.1<br>(101) | 2.0<br>(96) |
| 8.5<br>(2.59)         | 9<br>(230)  | 9<br>(230)   | 9<br>(230)   | 9<br>(230)   | 9<br>(230)   | 9<br>(230)   | 12<br>(300)  | 12<br>(300)  | 12<br>(300)  | 12<br>(300)  | 12<br>(300)  | 15<br>(375)  | 15<br>(375)  | 15<br>(375)  | 15<br>(375)  | 18<br>(450)  | 18<br>(450)  | 18<br>(450)  | 21<br>(525)  | 21<br>(525)  | 24<br>(600)  | 24<br>(600) |
| 9.0<br>(2.74)         | 9<br>(230)  | 9<br>(230)   | 9<br>(230)   | 9<br>(230)   | 9<br>(230)   | 12<br>(300)  | 12<br>(300)  | 12<br>(300)  | 12<br>(300)  | 12<br>(300)  | 15<br>(375)  | 15<br>(375)  | 15<br>(375)  | 15<br>(375)  | 18<br>(450)  | 18<br>(450)  | 18<br>(450)  | 21<br>(525)  | 21<br>(525)  | 24<br>(600)  | 24<br>(600)  | 27<br>(675) |
| 9.5<br>(2.90)         | 9<br>(230)  | 9<br>(230)   | 9<br>(230)   | 9<br>(230)   | 12<br>(300)  | 12<br>(300)  | 12<br>(300)  | 12<br>(300)  | 12<br>(300)  | 15<br>(375)  | 15<br>(375)  | 15<br>(375)  | 15<br>(375)  | 18<br>(450)  | 18<br>(450)  | 18<br>(450)  | 21<br>(525)  | 21<br>(525)  | 21<br>(525)  | 24<br>(600)  | 24<br>(600)  | 27<br>(675) |
| 10.0<br>(3.05)        | 9<br>(230)  | 9<br>(230)   | 12<br>(300)  | 12<br>(300)  | 12<br>(300)  | 12<br>(300)  | 12<br>(300)  | 12<br>(300)  | 15<br>(375)  | 15<br>(375)  | 15<br>(375)  | 15<br>(375)  | 18<br>(450)  | 18<br>(450)  | 18<br>(450)  | 21<br>(525)  | 21<br>(525)  | 21<br>(525)  | 24<br>(600)  | 24<br>(600)  | 27<br>(675)  | 27<br>(675) |
| 10.5<br>(3.20)        | 9<br>(230)  | 12<br>(300)  | 12<br>(300)  | 12<br>(300)  | 12<br>(300)  | 12<br>(300)  | 15<br>(375)  | 15<br>(375)  | 15<br>(375)  | 15<br>(375)  | 15<br>(375)  | 18<br>(450)  | 18<br>(450)  | 18<br>(450)  | 21<br>(525)  | 21<br>(525)  | 21<br>(525)  | 24<br>(600)  | 24<br>(600)  | 27<br>(675)  | 27<br>(675)  | 30<br>(750) |
| 11.0<br>(3.35)        | 12<br>(300)   | 12<br>(300)  | 12<br>(300)  | 12<br>(300)  | 12<br>(300)  | 15<br>(375)  | 15<br>(375)  | 15<br>(375)  | 15<br>(375)  | 15<br>(375)  | 18<br>(450)  | 18<br>(450)  | 18<br>(450)  | 21<br>(525)  | 21<br>(525)  | 21<br>(525)  | 24<br>(600)  | 24<br>(600)  | 27<br>(675)  | 27<br>(675)  | 30<br>(750)  | 30<br>(750) |
| 11.5<br>(3.50)        | 12<br>(300)   | 12<br>(300)  | 12<br>(300)  | 12<br>(300)  | 15<br>(375)  | 15<br>(375)  | 15<br>(375)  | 15<br>(375)  | 15<br>(375)  | 18<br>(450)  | 18<br>(450)  | 18<br>(450)  | 21<br>(525)  | 21<br>(525)  | 21<br>(525)  | 24<br>(600)  | 24<br>(600)  | 24<br>(600)  | 27<br>(675)  | 27<br>(675)  | 30<br>(750)  | 33<br>(825) |
| 12.0<br>(3.66)        | 12<br>(300)   | 12<br>(300)  | 12<br>(300)  | 15<br>(375)  | 15<br>(375)  | 15<br>(375)  | 15<br>(375)  | 15<br>(375)  | 18<br>(450)  | 18<br>(450)  | 18<br>(450)  | 21<br>(525)  | 21<br>(525)  | 21<br>(525)  | 24<br>(600)  | 24<br>(600)  | 24<br>(600)  | 27<br>(675)  | 27<br>(675)  | 30<br>(750)  | 30<br>(750)  | 33<br>(825) |

**Note:** The design engineer is solely responsible for assessing the bearing resistance (allowable bearing capacity) of the subgrade soils and determining the depth of foundation stone. Subgrade bearing resistance should be assessed with consideration for the range of soil moisture conditions expected under a stormwater system.

# 5.0 Cumulative Storage Volumes

Tables 4, 5, 6 and 7 provide cumulative storage volumes for the SC-160LP, SC-310, SC-740 and DC-780 chamber systems. This information may be used to calculate a detention/retention system's stage storage volume. A spreadsheet is available at [www.stormtech.com](http://www.stormtech.com) in which the number of chambers can be input for quick cumulative storage calculations.  
 Product Specifications: 1.1, 2.2, 2.3, 2.4, and 2.6

**Table 4 - SC-160LP Cumulative Storage Volumes Per Chamber**

Assumes 40% Stone Porosity. Calculations are Based Upon a 4" (100 mm) Stone Base Under the Chambers.

| Depth of Water in System Inches (mm) | Cumulative Chamber Storage ft <sup>3</sup> (m <sup>3</sup> ) | Total System Cumulative Storage ft <sup>3</sup> (m <sup>3</sup> ) |
|--------------------------------------|--|---|
| 22 (559)                             | 6.85 (0.194)   | 14.98 (0.424)   |
| 21 (533)                             | 6.85 (0.194)   | 14.49 (0.410)   |
| 20 (508)                             | 6.85 (0.194)   | 14.00 (0.396)   |
| 19 (483)                             | 6.85 (0.194)   | 13.50 (0.382)   |
| 18 (457)                             | 6.85 (0.194)   | 13.01 (0.368)   |
| 17 (432)                             | 6.85 (0.194)   | 12.51 (0.354)   |
| 16 (406)                             | 6.85 (0.194)   | 12.02 (0.340)   |
| 15 (381)                             | 6.80 (0.193)   | 11.49 (0.325)   |
| 14 (356)                             | 6.67 (0.189)   | 10.92 (0.309)   |
| 13 (330)                             | 6.38 (0.181)   | 10.25 (0.290)   |
| 12 (305)                             | 5.94 (0.168)   | 9.49 (0.269)  |
| 11 (279)                             | 5.40 (0.153)   | 8.67 (0.246)  |
| 10 (254)                             | 4.78 (0.135)   | 7.81 (0.221)  |
| 9 (229)                              | 4.10 (0.116)   | 6.91 (0.196)  |
| 8 (203)                              | 3.36 (0.095)   | 5.97 (0.169)  |
| 7 (178)                              | 2.58 (0.073)   | 5.01 (0.142)  |
| 6 (152)                              | 1.76 (0.050)   | 4.02 (0.114)  |
| 5 (127)                              | 0.89 (0.025)   | 3.01 (0.085)  |
| 4 (102)                              | 0 (0)  | 1.98 (0.056)  |
| 3 (76)                               | 0 (0)  | 1.48 (0.042)  |
| 2 (51)                               | 0 (0)  | 0.99 (0.028)  |
| 1 (25)                               | 0 (0)  | 0.49 (0.014)  |

Note: Add 0.49 ft<sup>3</sup> (0.014 m<sup>3</sup>) of storage for each additional inch (25 mm) of stone foundation.

**Table 5 - SC-310 Cumulative Storage Volumes Per Chamber**

Assumes 40% Stone Porosity. Calculations are Based Upon a 6" (150 mm) Stone Base Under the Chambers.

| Depth of Water in System Inches (mm) | Cumulative Chamber Storage ft <sup>3</sup> (m <sup>3</sup> ) | Total System Cumulative Storage ft <sup>3</sup> (m <sup>3</sup> ) |
|--------------------------------------|--|---|
| 28 (711)                             | 14.70 (0.416)  | 31.00 (0.878)   |
| 27 (686)                             | 14.70 (0.416)  | 30.21 (0.855)   |
| 26 (680)                             | 14.70 (0.416)  | 29.42 (0.833)   |
| 25 (635)                             | 14.70 (0.416)  | 28.63 (0.811)   |
| 24 (610)                             | 14.70 (0.416)  | 27.84 (0.788)   |
| 23 (584)                             | 14.70 (0.416)  | 27.05 (0.766)   |
| 22 (559)                             | 14.70 (0.416)  | 26.26 (0.748)   |
| 21 (533)                             | 14.64 (0.415)  | 25.43 (0.720)   |
| 20 (508)                             | 14.49 (0.410)  | 24.54 (0.695)   |
| 19 (483)                             | 14.22 (0.403)  | 23.58 (0.668)   |
| 18 (457)                             | 13.68 (0.387)  | 22.47 (0.636)   |
| 17 (432)                             | 12.99 (0.368)  | 21.25 (0.602)   |
| 16 (406)                             | 12.17 (0.345)  | 19.97 (0.566)   |
| 15 (381)                             | 11.25 (0.319)  | 18.62 (0.528)   |
| 14 (356)                             | 10.23 (0.290)  | 17.22 (0.488)   |
| 13 (330)                             | 9.15 (0.260)   | 15.78 (0.447)   |
| 12 (305)                             | 7.99 (0.227)   | 14.29 (0.425)   |
| 11 (279)                             | 6.78 (0.192)   | 12.77 (0.362)   |
| 10 (254)                             | 5.51 (0.156)   | 11.22 (0.318)   |
| 9 (229)                              | 4.19 (0.119)   | 9.64 (0.278)  |
| 8 (203)                              | 2.83 (0.081)   | 8.03 (0.227)  |
| 7 (178)                              | 1.43 (0.041)   | 6.40 (0.181)  |
| 6 (152)                              | 0  | 4.74 (0.134)  |
| 5 (127)                              | 0  | 3.95 (0.112)  |
| 4 (102)                              | 0  | 3.16 (0.090)  |
| 3 (76)                               | 0  | 2.37 (0.067)  |
| 2 (51)                               | 0  | 1.58 (0.046)  |
| 1 (25)                               | 0  | 0.79 (0.022)  |

Note: Add 0.79 ft<sup>3</sup> (0.022 m<sup>3</sup>) of storage for each additional inch (25 mm) of stone foundation.

# 5.0 Cumulative Storage Volumes

**Table 6 - SC-740 Cumulative Storage Volumes Per Chamber**

Assumes 40% Stone Porosity. Calculations are Based Upon a 6" (150 mm) Stone Base Under the Chambers.

| Depth of Water in System Inches (mm) | Cumulative Chamber Storage ft <sup>3</sup> (m <sup>3</sup> ) | Total System Cumulative Storage ft <sup>3</sup> (m <sup>3</sup> ) |
|--------------------------------------|--|---|
| 42 (1067)                            | 45.90 (1.300)  | 74.90 (2.121)   |
| 41 (1041)                            | 45.90 (1.300)  | 73.77 (2.089)   |
| 40 (1016)                            | 45.90 (1.300)  | 72.64 (2.057)   |
| 39 (991)                             | 45.90 (1.300)  | 71.52 (2.025)   |
| 38 (965)                             | 45.90 (1.300)  | 70.39 (1.993)   |
| 37 (948)                             | 45.90 (1.300)  | 69.26 (1.961)   |
| 36 (914)                             | 45.90 (1.300)  | 68.17 (1.929)   |
| 35 (889)                             | 45.85 (1.298)  | 66.98 (1.897)   |
| 34 (864)                             | 45.69 (1.294)  | 65.75 (1.862)   |
| 33 (838)                             | 45.41 (1.286)  | 64.46 (1.825)   |
| 32 (813)                             | 44.81 (1.269)  | 62.97 (1.783)   |
| 31 (787)                             | 44.01 (1.246)  | 61.36 (1.737)   |
| 30 (762)                             | 43.06 (1.219)  | 59.66 (1.689)   |
| 29 (737)                             | 41.98 (1.189)  | 57.89 (1.639)   |
| 28 (711)                             | 40.80 (1.155)  | 56.05 (1.587)   |
| 27 (686)                             | 39.54 (1.120)  | 54.17 (1.534)   |
| 26 (660)                             | 38.18 (1.081)  | 52.23 (1.479)   |
| 25 (635)                             | 36.74 (1.040)  | 50.23 (1.422)   |
| 24 (610)                             | 35.22 (0.977)  | 48.19 (1.365)   |
| 23 (584)                             | 33.64 (0.953)  | 46.11 (1.306)   |
| 22 (559)                             | 31.99 (0.906)  | 44.00 (1.246)   |
| 21 (533)                             | 30.29 (0.858)  | 41.85 (1.185)   |
| 20 (508)                             | 28.54 (0.808)  | 39.67 (1.123)   |
| 19 (483)                             | 26.74 (0.757)  | 37.47 (1.061)   |
| 18 (457)                             | 24.89 (0.705)  | 35.23 (0.997)   |
| 17 (432)                             | 23.00 (0.651)  | 32.69 (0.939)   |
| 16 (406)                             | 21.06 (0.596)  | 30.68 (0.869)   |
| 15 (381)                             | 19.09 (0.541)  | 28.36 (0.803)   |
| 14 (356)                             | 17.08 (0.484)  | 26.03 (0.737)   |
| 13 (330)                             | 15.04 (0.426)  | 23.68 (0.670)   |
| 12 (305)                             | 12.97 (0.367)  | 21.31 (0.608)   |
| 11 (279)                             | 10.87 (0.309)  | 18.92 (0.535)   |
| 10 (254)                             | 8.74 (0.247)   | 16.51 (0.468)   |
| 9 (229)                              | 6.58 (0.186)   | 14.09 (0.399)   |
| 8 (203)                              | 4.41 (0.125)   | 11.66 (0.330)   |
| 7 (178)                              | 2.21 (0.063)   | 9.21 (0.264)  |
| 6 (152)                              | 0  | 6.76 (0.191)  |
| 5 (127)                              | 0  | 5.63 (0.160)  |
| 4 (102)                              | 0  | 4.51 (0.125)  |
| 3 (76)                               | 0  | 3.38 (0.095)  |
| 2 (51)                               | 0  | 2.25 (0.064)  |
| 1 (25)                               | 0  | 1.13 (0.032)  |

Note: Add 1.13 ft<sup>3</sup> (0.032 m<sup>3</sup>) of storage for each additional inch (25 mm) of stone foundation.

**Table 7 - DC-780 Cumulative Storage Volumes Per Chamber**

Assumes 40% Stone Porosity. Calculations are Based Upon a 9" (230 mm) Stone Base Under the Chambers.

| Depth of Water in System Inches (mm) | Cumulative Chamber Storage ft <sup>3</sup> (m <sup>3</sup> ) | Total System Cumulative Storage ft <sup>3</sup> (m <sup>3</sup> ) |
|--------------------------------------|--|---|
| 45 (1143)                            | 46.27 (1.310)  | 78.47 (2.222)   |
| 44 (1118)                            | 46.27 (1.310)  | 77.34 (2.190)   |
| 43 (1092)                            | 46.27 (1.310)  | 76.21 (2.158)   |
| 42 (1067)                            | 46.27 (1.310)  | 75.09 (2.126)   |
| 41 (1041)                            | 46.27 (1.310)  | 73.96 (2.094)   |
| 40 (1016)                            | 46.27 (1.310)  | 72.83 (2.062)   |
| 39 (991)                             | 46.27 (1.310)  | 71.71 (2.030)   |
| 38 (965)                             | 46.21 (1.309)  | 70.54 (1.998)   |
| 37 (948)                             | 46.04 (1.304)  | 69.32 (1.963)   |
| 36 (914)                             | 45.76 (1.296)  | 68.02 (1.926)   |
| 35 (889)                             | 45.15 (1.278)  | 66.53 (1.884)   |
| 34 (864)                             | 44.34 (1.255)  | 64.91 (1.838)   |
| 33 (838)                             | 43.38 (1.228)  | 63.21 (1.790)   |
| 32 (813)                             | 42.29 (1.198)  | 61.43 (1.740)   |
| 31 (787)                             | 41.11 (1.164)  | 59.59 (1.688)   |
| 30 (762)                             | 39.83 (1.128)  | 57.70 (1.634)   |
| 29 (737)                             | 38.47 (1.089)  | 55.76 (1.579)   |
| 28 (711)                             | 37.01 (1.048)  | 53.76 (1.522)   |
| 27 (686)                             | 35.49 (1.005)  | 51.72 (1.464)   |
| 26 (660)                             | 33.90 (0.960)  | 49.63 (1.405)   |
| 25 (635)                             | 32.24 (0.913)  | 47.52 (1.346)   |
| 24 (610)                             | 30.54 (0.865)  | 45.36 (1.285)   |
| 23 (584)                             | 28.77 (0.815)  | 43.18 (1.223)   |
| 22 (559)                             | 26.96 (0.763)  | 40.97 (1.160)   |
| 21 (533)                             | 25.10 (0.711)  | 38.72 (1.096)   |
| 20 (508)                             | 23.19 (0.657)  | 36.45 (1.032)   |
| 19 (483)                             | 21.25 (0.602)  | 34.16 (0.967)   |
| 18 (457)                             | 19.26 (0.545)  | 31.84 (0.902)   |
| 17 (432)                             | 17.24 (0.488)  | 29.50 (0.835)   |
| 16 (406)                             | 15.19 (0.430)  | 27.14 (0.769)   |
| 15 (381)                             | 13.10 (0.371)  | 24.76 (0.701)   |
| 14 (356)                             | 10.98 (0.311)  | 22.36 (0.633)   |
| 13 (330)                             | 8.83 (0.250)   | 19.95 (0.565)   |
| 12 (305)                             | 6.66 (0.189)   | 17.52 (0.496)   |
| 11 (279)                             | 4.46 (0.126)   | 15.07 (0.427)   |
| 10 (254)                             | 2.24 (0.064)   | 12.61 (0.357)   |
| 9 (229)                              | 0  | 10.14 (0.287)   |
| 8 (203)                              | 0  | 9.01 (0.255)  |
| 7 (178)                              | 0  | 7.89 (0.223)  |
| 6 (152)                              | 0  | 6.76 (0.191)  |
| 5 (127)                              | 0  | 5.63 (0.160)  |
| 4 (102)                              | 0  | 4.51 (0.128)  |
| 3 (76)                               | 0  | 3.38 (0.096)  |
| 2 (51)                               | 0  | 2.25 (0.064)  |
| 1 (25)                               | 0  | 1.13 (0.032)  |

Note: Add 1.13 ft<sup>3</sup> (0.032 m<sup>3</sup>) of storage for each additional inch (25 mm) of stone foundation.

# 6.0 Required Materials/Row Separation

## 6.1 Chamber Row Separation

StormTech SC-740, SC-310 and DC-780 chambers must be specified with a minimum 6 (150 mm) space between the feet of adjacent parallel chamber rows. No spacing is required between the SC-160LP chambers. Increasing the space between rows is acceptable. This will increase the storage volume due to additional stone voids.

## 6.2 Stone Surrounding Chambers

Refer to **Table 8** for acceptable stone materials. StormTech requires clean, crushed, angular stone below, between and above chambers as shown in **Figure 6**. Acceptable gradations are listed in **Table 8**. Subrounded and rounded stone are not acceptable.

## 6.3 Geotextile Separation Requirement

A non-woven geotextile that meets AASHTO M288 Class 2 Separation requirements must be applied as a separation layer to prevent soil intrusion into the clean, crushed,

angular stone as shown in **Figure 6**. The geotextile is required between the clean, crushed, angular stone and the subgrade soils, the excavation's sidewalls and the fill materials. The geotextile should completely envelope the clean, crushed, angular stone. Overlap adjacent geotextile rolls per AASHTO M288 separation guidelines. Contact StormTech for a list of acceptable geotextiles.

## 6.4 Fill Above Chambers

Refer to **Table 8** and **Figure 6** for acceptable fill material above the 6 (150 mm) of clean, crushed, angular stone. Minimum and maximum fill requirements for the SC-160LP, SC-740, SC-310 and DC-780 chambers are shown in **Figure 6** below. StormTech requires a minimum of 24 (600 mm) of fill in non-paved installations where rutting from vehicles may occur. **Table 8** provides details on soil class and compaction requirements for suitable fill materials.

**Table 8 – Acceptable Fill Materials**

| Material Location | Description  | AASHTO Material Classifications   | Compaction / Density Requirement  |
|-------------------|--|---|---|
| <b>D</b>          | <b>Final Fill:</b> Fill material for layer 'D' starts from the top of the 'C' layer to the bottom of the flexible pavement to unpaved finished grade above. Note that pavement subbase may be part of the 'D' layer. | N/A   | Prepare per site design Engineer's plans. Paved installations may have stringent material and preparation requirements.   |
| <b>C</b>          | <b>Initial Fill:</b> Fill material for layer 'C' starts from the top of the embedment stone ('B' Layer) to 18 (450 mm) above the top of the chamber. Note that pavement subbase may be a part of the 'C' layer.      | AASHTO M145 <sup>1</sup><br>A-1, A-2-4, A-3<br>OR<br>AASHTO M43 <sup>3</sup><br>3, 357, 4, 467, 5, 56, 57, 6, 67, 68, 7, 78, 8, 89, 9, 10 | Begin Compactions after 12 (300 mm) of material over the chambers is reached. Compact additional layers in 6 (150 mm) max lifts to a min. 95% proctor density for well graded material and 95% relative Density for processed aggregate materials. Roller gross vehicle weight not to exceed 12,000 lbs (53 kN). Dynamic force not to exceed 20,000 lbs (89 kN) |
| <b>B</b>          | <b>Embedment stone:</b> Fill surrounding the chambers from the foundation stone ('A' layer) to the 'C' layer above   | AASHTO M145 <sup>1</sup><br>3, 357, 4, 467, 5, 56, 57   | No compaction required.   |
| <b>A</b>          | <b>Foundation stone:</b> Fill below chambers from the subgrade up to the foot (bottom) of the chamber.   | AASHTO M145 <sup>1</sup><br>3, 357, 4, 467, 5, 56, 57   | Plate compact or roll to achieve a flat surface. <sup>2,3</sup>   |

Please Note:

- The listed AASHTO designations are for gradations only. The stone must also be clean, crushed, angular. For example, a specification for #4 Stone would state: clean, crushed, angular No. 4 (AASHTO M43) Stone.
- StormTech compaction requirements are met for 'A' location materials when placed and compacted in 6 (150 mm) (MAX) Lifts using two full coverages with a vibratory compactor.
- Where infiltration surfaces may be compromised by compaction, for standard design load conditions, a flat surface may be achieved by raking or dragging without compaction equipment. For special load designs, contact StormTech for compaction requirements.

**Figure 6 – Fill Material Locations**

Once layer 'C' is placed any soil/material can be placed in layer 'D' up to the finished grade. Most pavement subbase soils can be used to replace the materials requirements of layer 'C' or 'D' at the design engineer's discretion.

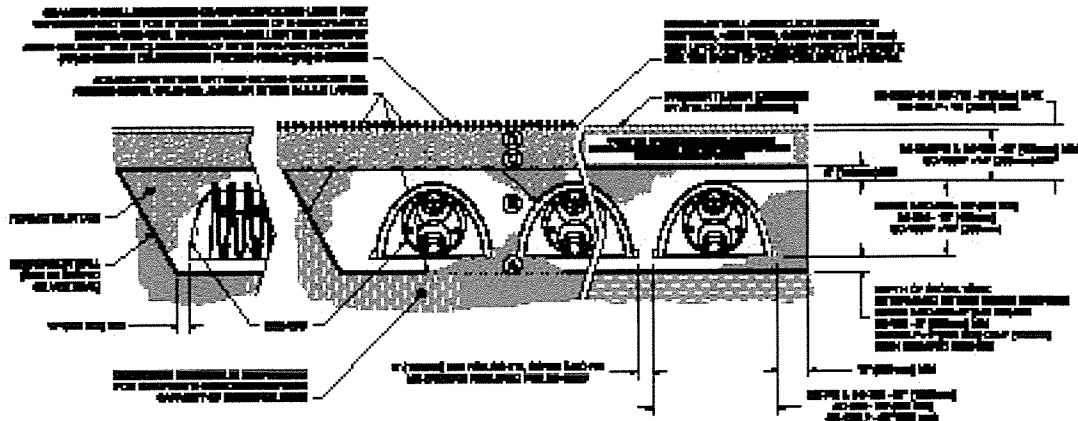

## 7.0 Inletting the Chambers

The design flexibility of a StormTech chamber system includes many inletting possibilities. Contact StormTech's Technical Service Department for guidance on designing an inlet system to meet specific site goals.

### 7.1 Treatment Train

A properly designed inlet system can ensure good water quality, easy inspection and maintenance, and a long system service life. StormTech recommends a treatment train approach for inletting an underground stormwater management system under a typical commercial parking area. Treatment train is an industry term for a multi-tiered water quality network. As shown in **Figure 7**, a StormTech recommended inlet system can inexpensively have tiers of treatment upstream of the StormTech chambers:

**Tier 1 - Pre-treatment (BMP)**

**Tier 2 - StormTech Isolator<sup>®</sup> Row Plus**

**Tier 3 - Enhanced Treatment (BMP)**

**Figure 7 - Typical StormTech Treatment Train Inlet System**

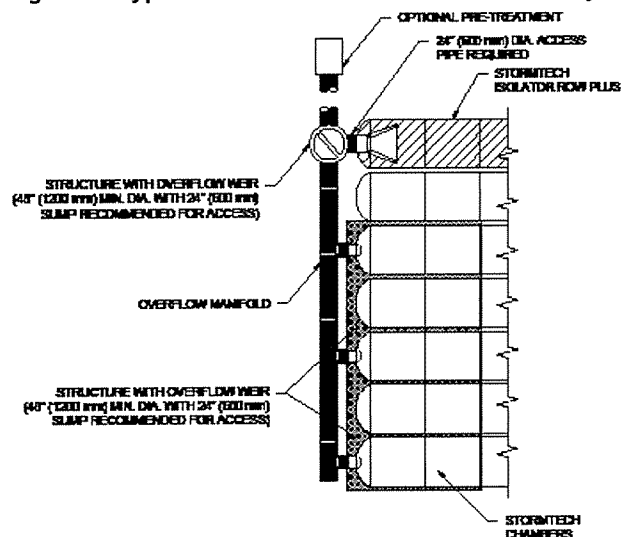

### 7.2 Pre-Treatment (BMP) - Treatment Tier 1

In some areas pre-treatment of the stormwater is required prior to entry into a stormwater system. By treating the stormwater prior to entry into the system, the service life of the system can be extended, pollutants such as hydrocarbons may be captured, and local regulations met. Pre-treatment options are often described as a Best Management Practice or simply a BMP.

Pre-treatment devices differ greatly in complexity, design and effectiveness. Depending on a site's characteristics and treatment goals, the simple, least expensive pretreatment solutions can sometimes be just as effective as the complex systems. Options include a simple deep sumped manhole with a 90° bend on its outlet, baffle boxes, swirl concentrators, and devices that combine these processes. Some of the most effective pretreatment options combine engineered site grading with vegetation such as bio-swales or grassy strips.

The type of pretreatment device specified as the first level of treatment up-stream of a StormTech chamber system can vary greatly throughout the country and from site-to-site. It is the responsibility of the design engineer to understand the water quality requirements and design a stormwater treatment system that will satisfy local regulators and follow applicable laws. A design engineer should apply their understanding of local weather conditions, site topography, local maintenance requirements, expected service life, etc. to select an appropriate stormwater pre-treatment system.

### 7.3 StormTech Isolator Row Plus - Treatment Tier 2

StormTech has a patented technique to inexpensively enhance Total Suspended Solids (TSS) removal and provide easy access for inspection and maintenance. The StormTech Isolator Row Plus is a row of standard StormTech chambers surrounded with appropriate filter fabrics and connected to a manhole for easy access. This application basically creates a filter/detention basin that allows water to egress through the surrounding filter fabric while sediment is trapped within. It may be best to think of the Isolator Row Plus as a first-flush treatment device. First-Flush is a term typically used to describe the first 1/2 to 1 (13-25 mm) of rainfall or runoff on a site. The majority of stormwater pollutants are carried in the sediments of the firstflush, therefore the Isolator Row Plus is an effective component of a treatment train.

The StormTech Isolator Row Plus should be designed with a manhole with an overflow weir at its upstream end. The diversion manhole is multi-purposed. It can provide access to the Isolator Row Plus for both inspection and maintenance and acts as a diversion structure. The manhole is connected to the Isolator Row Plus with a short length of 8 (200mm) pipe for the SC-160LP chambers, 12 (300 mm) pipe for the SC-310 chamber and 24 (600 mm) pipe for the SC-740 and DC-780 chambers. These pipes are connected to the Isolator Row Plus with an 8 (200mm) precored end cap for the SC-160LP, a 12 (300 mm) fabricated end cap for the SC-310 chamber and a 24 (600 mm) fabricated end cap for the SC-740 and DC-780 chambers. The overflow weir typically has its crest set between the top of the chamber and its midpoint. This allows storm water in excess of the Isolator Row Plus's storage/conveyance capacity to bypass into the chamber system through the downstream manifold system.

Specifying and installing proper geotextiles is essential for efficient operation and to prevent damage to the system during the JetVac maintenance process. In a typical configuration, a single layer of ADS Plus fabric is placed between the chambers and stone foundation. This fabric traps and filters sediments as well as protects the stone base during cleaning and maintenance. A strip of non-woven AASHTO M288 Class 2 geotextile is draped over the Isolator Plus chamber row. This 6-8 oz. (217-278 g/m<sup>2</sup>) nonwoven filter fabric



## 7.0 Inletting the Chambers

**Figure 8 – StormTech Isolator Row PLUS Detail**

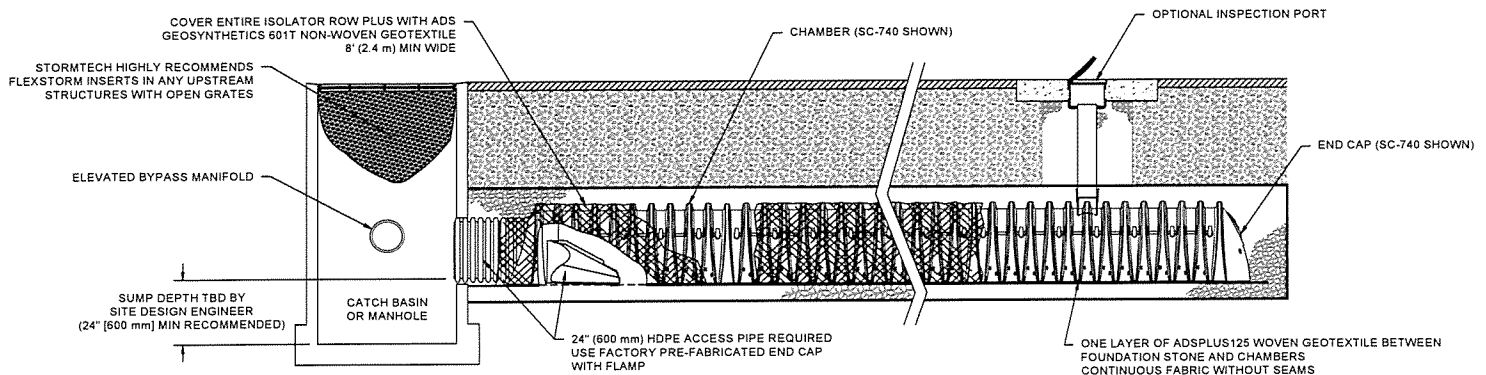

**Note:** Non-woven geotextile over DC-780 Isolator Row PLUS chambers is not required.

prevents sediments from migrating out of the chamber perforations while allowing modest amounts of water to flow out of the Isolator Row Plus. **Figure 8** is a detail of the Isolator Row Plus that shows proper application of the geotextiles. Contact StormTech for a table of acceptable geotextiles.

For SC-310 and SC-740 Isolator Plus Rows, a FLAMP (flared end ramp) is attached to the inlet pipe on the inside of the chamber end cap to provide a smooth transition from pipe invert to fabric bottom. It is configured to improve chamber function performance over time by distributing sediment and debris that would otherwise collect at the inlet. It also serves to improve the fluid and solid flow back into the inlet pipe during maintenance and cleaning, and to guide cleaning and inspection equipment back into the inlet pipe when complete.

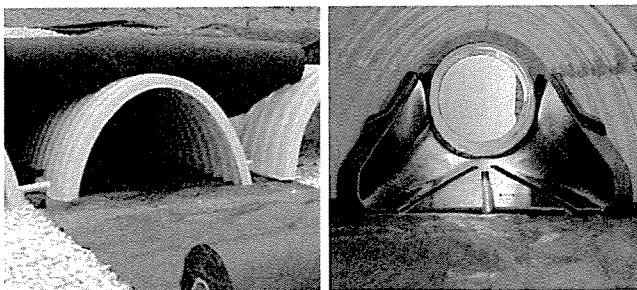

Inspection is easily accomplished through the upstream manhole or optional inspection ports. Maintenance of an Isolator Row Plus is fast and easy using the JetVac process through the upstream manhole. Section 12.0 explains the inspection and maintenance process in more detail.

Isolator Plus Rows can be sized to accommodate either a water quality volume or a water quality flow rate requirement. The use of filter fabric around the Isolator Row Plus chambers allows stormwater to egress out of the row during and between storm events. The rate of egression for design is dependent upon the chamber model and sediment accumulation on the geotextile.

Contact StormTech's Technical Services Department for more information on Isolator Row Plus sizing.

### 7.4 Enhanced Treatment (BMP) – Treatment Tier 3

As regulations have become more stringent, requiring higher levels of contaminant removal, water quality systems may be required to treat higher flow rates, greater volumes or to provide a higher level of filtration or other more sophisticated treatment process. StormTech systems can easily be configured with enhanced treatment techniques located either upstream or downstream of the retention or detention chamber system. Located upstream of an infiltration bed, between the pretreatment device and the Isolator Row Plus, enhanced treatment provides a high level of contaminant removal which protects groundwater or better preserves the infiltration surface. Located downstream of detention, enhanced treatment provides a higher level of contaminant removal prior to discharge to a receiving body.

Enhanced treatment BMPs are normally applied where specific regulations and specific water quality product approvals are in place. StormTech works closely with providers of enhanced treatment technologies to meet local requirements.

### 7.5 TREATMENT TRAIN CONCLUSION

The treatment train is a highly effective water-quality approach that may not add significant cost to a StormTech system being installed under commercial parking areas. The StormTech Isolator Row Plus adds a significant level of treatment, easy inspection and maintenance, while maintaining storage volume credit for the cost of a modest amount of geotextile. Finally where higher levels of treatment are required, StormTech can integrate other technologies into the treatment train to provide the most cost effective treatment approach. This treatment train concept provides three levels of treatment, inspection and maintenance upstream and downstream of the StormTech detention/retention bed.

## 7.0 Inletting the Chambers

### 7.6 Other Inlet Options

While the three-tiered treatment train approach is the recommended method of inletting StormTech chambers for typical under-commercial parking applications, there are other effective inlet methods that may be considered. For instance, the Isolator Row PLUS, while adding an inexpensive level of confidence, are not always necessary. A header system with fewer inlets can be designed to further minimize the cost of a StormTech system. There may be applications where stormwater pre-treatment may not be necessary at all and the system can be inlet directly from the source. Contact StormTech's Technical Service Department to discuss inlet options.

### 7.7 Lateral Flow Rates

The embedment stone surrounding the StormTech chambers allows the rapid conveyance of stormwater between chamber rows. Stormwater will rise and fall evenly within a bed of chambers. A single StormTech SC-740 chamber is able to release or accept stormwater at a rate of at least 0.5 cfs (14.2 l/s) through the surrounding stone.

### 7.8 Inletting Perpendicular to a Row of Chambers with Inserta Tee

There is an easy, inexpensive method to perpendicularly inlet a row of chambers. Simply connect the inlet directly to the chamber with an Inserta Tee. Figure 9 shows a typical detail along with the standard sizes offered for each chamber model.

**Figure 9 – Inserta Tee Side Detail**

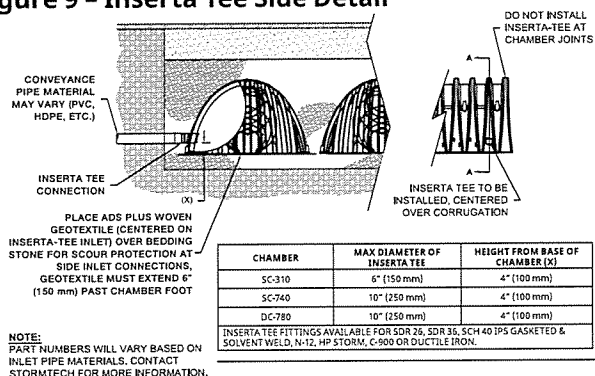

**NOTE:** Side Inserta Tees Cannot be used on SC-160LP Chambers.

### 7.9 Maximum Inlet Pipe Velocities to prevent Scouring of the Stone Foundation

The primary function of the inlet manifold is to convey and distribute flows to a sufficient number of rows in the chamber bed such that there is ample conveyance capacity to pass the peak flows without creating an unacceptable backwater condition in upstream piping or scour the foundation stone under the chambers.

Manifolds are connected to the end caps either at the top or bottom of the end cap. High inlet flow

rates from either connection location produce a shear scour potential of the foundation stone. Inlet flows from top inlets also produce impingement scour potential. Scour potential is reduced when standing water is present over the foundation stone. However, for safe design across the wide range of applications, StormTech assumes minimal standing water at the time the design flow occurs.

To minimize scour potential, StormTech recommends the installation of woven scour protection fabric at each inlet row. This enables a protected transition zone from the concentrated flow coming out of the inlet pipe to a uniform flow across the entire width of the chamber for both top and bottom connections. Allowable flow rates for design are dependent upon: the elevation of inlet pipe, foundation stone size and scour protection. An appropriate scour protection geotextile is installed from the end cap to at least 10.5' (3.2 m) for the SC-310, SC-740 and DC 780 chambers for both top and bottom feeding inlet pipes.

See StormTech's Tech Note 6.32 for guidance on manifold sizing. ADS's Technical Services department can also assist with sizing inlet manifolds for the StormTech chamber systems.

**Table 9A – Standard Distances from Base of Chamber to Invert of Inlet and Outlet Manifolds on StormTech End Caps**

| SC-160LP End Caps |                  |           |           |           |
|-------------------|------------------|-----------|-----------|-----------|
|                   | Pipe Diameter    | Inv. (in) | Inv. (ft) | Inv. (mm) |
|                   | 6 (150 mm)       | 0.66      | 0.05      | 16        |
|                   | 8 (200 mm)       | 0.80      | 0.07      | 20        |
|                   | 8 (200 mm) Cored | 0.96      | 0.08      | 24        |

| SC-310 End Caps |               |             |           |           |    |
|-----------------|---------------|-------------|-----------|-----------|----|
|                 | Pipe Diameter | Inv. (in)   | Inv. (ft) | Inv. (mm) |    |
| TOP             | 6 (150 mm)    | 5.8         | 0.48      | 146       |    |
|                 | 8 (200 mm)    | 3.5         | 0.29      | 88        |    |
|                 | 10 (250 mm)   | 1.4         | 0.12      | 37        |    |
|                 | BOTTOM        | 6 (150 mm)  | 0.5       | 0.04      | 12 |
|                 |               | 8 (200 mm)  | 0.6       | 0.05      | 15 |
|                 |               | 10 (250 mm) | 0.7       | 0.06      | 18 |
| 12 (750 mm)     |               | 0.9         | 0.08      | 24        |    |

| SC-740 / DC-780 End Caps |               |           |           |           |
|--------------------------|---------------|-----------|-----------|-----------|
|                          | Pipe Diameter | Inv. (in) | Inv. (ft) | Inv. (mm) |
| TOP                      | 6 (150 mm)    | 18.5      | 1.54      | 469       |
|                          | 8 (200 mm)    | 16.5      | 1.38      | 421       |
|                          | 10 (250 mm)   | 14.5      | 1.21      | 369       |
|                          | 12 (300 mm)   | 12.5      | 1.04      | 317       |
|                          | 15 (375 mm)   | 9         | 0.75      | 229       |
|                          | 18 (450 mm)   | 5         | 0.42      | 128       |
| BOTTOM                   | 6 (150 mm)    | 0.5       | 0.04      | 12        |
|                          | 8 (200 mm)    | 0.6       | 0.05      | 15        |
|                          | 10 (250 mm)   | 0.7       | 0.06      | 18        |
|                          | 12 (750 mm)   | 1.2       | 0.10      | 30        |
|                          | 15 (900 mm)   | 1.3       | 0.11      | 34        |
|                          | 18 (1050 mm)  | 1.6       | 0.13      | 40        |
|                          | 24 (1200 mm)  | 0.1       | 0.01      | 3         |

\*See StormTech's Tech Sheet #7 for manifold sizing guidance\*

# 8.0 Outlets for Chambers

## 8.0 Outlets for StormTech Chamber Systems

The majority of StormTech installations are detention systems and have some type of outlet structure. An outlet manifold is generally designed to ensure that peak flows can be conveyed to the outlet structure.

To drain the system completely, an underdrain system is located at or below the bottom of the foundation stone. Some beds may be designed with a pitched base to ensure complete drainage of the system. A grade of 1/2% is usually satisfactory.

An outlet pipe may be located at a higher invert within a bed. This allows a designed volume of water to infiltrate while excess volumes are outlet as necessary. This is an excellent method of recharging groundwater, replicating a site's pre-construction hydraulics.

Depending on the bed layout and inverts, outlet pipes should be placed in the embedment stone along the bed's perimeter as shown in **Figures 10 and 11**. Solid outlet pipes should also be used to penetrate the StormTech end caps at the designed outlet invert as shown in **Figure 12**. An Isolator Row PLUS should not be directly penetrated with an outlet pipe. For systems requiring higher outlet flow rates, a combination of connections may be utilized as shown in **Figure 13**.

In detention and retention applications the discharge of water from the stormwater management system is determined based on the hydrology of the area and the hydraulic design of the system. It is the design engineer's responsibility to design an outlet system that meets their hydraulic objectives while following local laws and regulations.

**Table 9B - Maximum Outlet Flow Rate Capacities from StormTech Manifolds**

| Pipe Diameter | Outlet Flow |            |
|---------------|-------------|------------|
|               | Flow (CFS)  | Flow (L/S) |
| 6 (150 mm)    | 0.4         | 11.3       |
| 8 (200 mm)    | 0.7         | 19.8       |
| 10 (250 mm)   | 1.0         | 28.3       |
| 12 (300 mm)   | 2.0         | 56.6       |
| 15 (375 mm)   | 2.7         | 76.5       |
| 18 (450 mm)   | 4.0         | 113.3      |
| 24 (600 mm)   | 7.0         | 198.2      |
| 30 (750 mm)   | 11.0        | 311.5      |
| 36 (900 mm)   | 16.0        | 453.1      |
| 42 (1050 mm)  | 22.0        | 623.0      |
| 48 (1200 mm)  | 28.0        | 792.9      |

**Figure 10 - Underdrain Parallel**

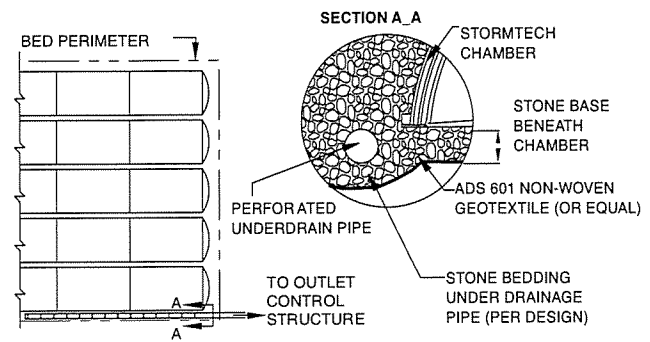

**Figure 11 - Underdrain Perpendicular**

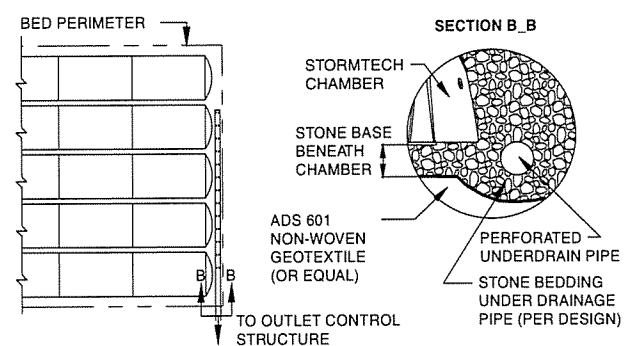

**Figure 12 - Outlet Manifold**

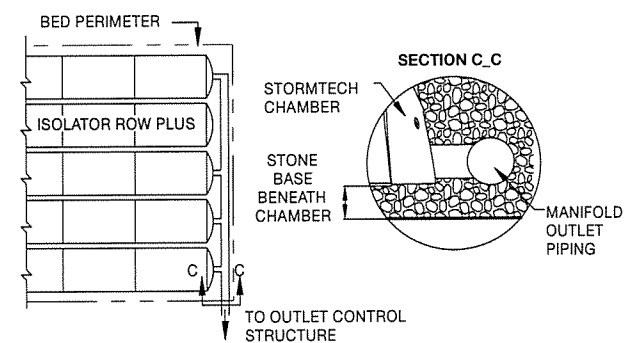

**Figure 13 - Combination Outlet**

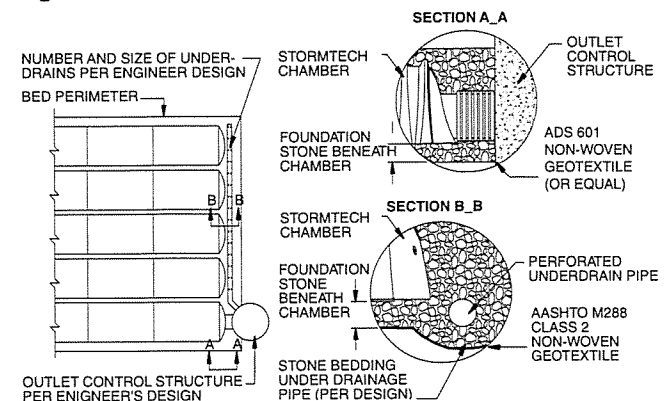

## 9.0 Other Considerations

### 9.1 Erosion Control

Erosion and sediment control measures must be integrated into the plan to protect the stormwater system both during and after construction. These practices may have a direct impact on the system's infiltration performance and longevity. Vegetation, temporary sediment barriers (silt fences, hay bales, fabric-wrapped catch basin grates), and strategic stormwater runoff management may be used to control erosion and sedimentation. StormTech recommends the use of pipe plugs on the inlet pipe until the system is in service.

### 9.2 SITE IMPROVEMENT TECHNIQUES

When site conditions are less than optimal, StormTech recognizes many methods for improving a site for construction. Some techniques include the removal and replacement of poor materials, the use of engineered subgrade materials, aggregates, chemical treatment, and mechanical treatments including the use of geosynthetics. StormTech recommends referring to AASHTO M 288 guidelines for the appropriate use of geotextiles.

StormTech also recognizes geogrid as a potential component of an engineered solution to improve site conditions or as a construction tool for the experienced contractor. StormTech chamber systems are compatible with the use of geosynthetics. The use of geosynthetics or any other site improvement method does not eliminate or modify any of StormTech's requirements. **It is the ultimate responsibility of the design engineer to ensure that site conditions are suitable for a StormTech chamber system.**

### 9.3 CONFORMING TO SITE CONSTRAINTS

StormTech chambers have the unique ability to conform to site constraints such as utility lines, light posts, etc. Rows of chambers can be ended short or interrupted by placing an end cap at the desired location, leaving the required number of chambers out of the row to get by the obstruction, then starting the row of chambers again with another end cap. See **Figure 14** for an example.

**Figure 14 - Ability to Conform to Site Constraints**

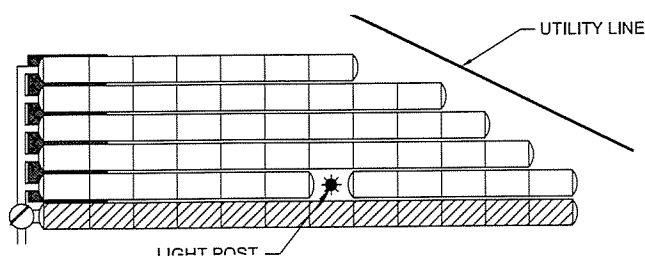

### 9.4 LINERS

StormTech chambers offer the distinct advantage and versatility that allow them to be designed as an open bottom detention or retention system. In fact, the vast majority of StormTech installations and designs are open bottom detention systems. Using an open bottom system enables treatment of the storm water through the underlying soils and provides a volume safety factor based on the infiltrative capacity of the underlying soils.

In some applications, however, open bottom detention systems may not be allowed. StormTech's Tech Sheet #2 provides guidance for the design and installation of thermoplastic liners for detention systems using StormTech chambers. The major points of the memo are:

- Infiltration of stormwater is generally a desirable stormwater management practice, often required by regulations. Lined systems should only be specified where unique site conditions preclude significant infiltration.
- Thermoplastic liners provide cost effective and viable means to contain stormwater in StormTech subsurface systems where infiltration is undesirable.
- PVC and LLDPE are the most cost effective, installed membrane materials.
- Enhanced puncture resistance from angular aggregate on the water side and from protrusions on the soil side can be achieved by placing a non-woven geotextile reinforcement on each side of the geomembrane. A sand underlayment in lieu of the geotextile reinforcement on the soil side may be considered when cost effective.
- StormTech does not design, fabricate, sell or install thermoplastic liners. StormTech recommends consulting with liner professionals for final design and installation advice.

**Figure 15 - Chamber bed placed around light post.**



## 10.0 System Sizing

For quick calculations, refer to the Site Calculator on StormTech's website at [www.stormtech.com](http://www.stormtech.com).

### 10.1 System Sizing

The following steps provide the calculations necessary to size a system. If you need assistance determining the number of chambers per row or customizing the bed configuration to fit a specific site, call StormTech's Technical Services Department at 1-888-892-2694.

#### 1) Determine the amount of storage volume ( $V_s$ ) required.

It is the design engineer's sole responsibility to determine the storage volume required by local codes.

**Table 10 - Storage Volume Per Chamber**

|          | Bare Chamber Storage<br>ft <sup>2</sup> (m <sup>2</sup> ) | Chamber and Stone Foundation Depth<br>in. (mm) |             |             |
|----------|---|--|-------------|-------------|
|          |   | 6 (150)  | 12 (300)    | 18 (450)    |
| SC-160LP | 6.85 (0.19)   | 15.0 (0.42)                                    | 17.9 (0.51) | 20.9 (0.59) |
| SC-310   | 14.7 (0.4)  | 31.0 (0.9)                                     | 35.7 (1.0)  | 40.4 (1.1)  |
| SC-740   | 45.9 (1.3)  | 74.9 (2.1)                                     | 81.7 (2.3)  | 88.4 (2.5)  |
|          | ft <sup>3</sup> (m <sup>3</sup> )                         | 9 (230)  | 12 (300)    | 18 (450)    |
| DC-780   | 46.2 (1.3)  | 78.4 (2.2)                                     | 81.8 (2.3)  | 88.6 (2.5)  |

Note: Assumes 40% porosity for the stone plus the chamber volume.

#### 2) Determine the number of chambers (C) required.

To calculate the number of chambers needed for adequate storage, divide the storage volume ( $V_s$ ) by the volume of the selected chamber, as follows:

$$C = V_s / \text{Volume per Chamber}$$

#### 3) Determine the required bed size (S).

To find the size of the bed, multiply the number of chambers needed (C) by either:

##### StormTech SC-160LP

bed area per chamber = 14.8 ft<sup>2</sup> (1.3 m<sup>2</sup>)

##### StormTech SC-310

bed area per chamber = 23.7 ft<sup>2</sup> (2.2 m<sup>2</sup>)

##### StormTech SC-740 / DC-780

bed area per chamber = 33.8 ft<sup>2</sup> (3.1 m<sup>2</sup>)

$$S = (C \times \text{bed area per chamber}) + [1 \text{ foot (0.3 m) } \times \text{bed perimeter in feet (meters)}]$$

NOTE: It is necessary to add one foot (0.3 m) around the perimeter of the bed for end caps and working space.

#### 4) Determine the amount of clean, crushed, angular stone (Vst) required.

**Table 11 – Amount of Stone Per Chamber**

| ENGLISH tons (yd <sup>3</sup> ) | Stone Foundation Depth |            |            |
|---------------------------------|------------------------|------------|------------|
|                                 | 6                      | 12         | 18         |
| SC-160LP                        | 1.2 (0.9)              | 1.6 (1.2)  | 1.9 (1.4)  |
| SC-310                          | 2.1 (1.5)              | 2.7 (1.9)  | 3.4 (2.4)  |
| SC-740                          | 3.8 (2.8)              | 4.6 (3.3)  | 5.5 (3.9)  |
| METRIC kg (m <sup>3</sup> )     | 150 mm                 | 300 mm     | 450 mm     |
| SC-160LP                        | 1088 (0.7)             | 1452 (0.9) | 1724 (1.0) |
| SC-310                          | 1830 (1.1)             | 2490 (1.5) | 2990 (1.8) |
| SC-740                          | 3450 (2.1)             | 4170 (2.5) | 4490 (3.0) |
| ENGLISH tons (yd <sup>3</sup> ) | 9                      | 12         | 18         |
| DC-780                          | 4.2 (3.0)              | 4.7 (3.3)  | 5.6 (3.9)  |
| METRIC kg (m <sup>3</sup> )     | 230 mm                 | 300 mm     | 450 mm     |
| DC-780                          | 3810 (2.3)             | 4264 (2.5) | 5080 (3.0) |

Note: Assumes 6 (150 mm) of stone above, and between chambers. For SC-310, SC-740 and DC-780 Chambers only.

To calculate the total amount of clean, crushed, angular stone required, multiply the number of chambers (C) by the selected weight of stone from **Table 11**.

**NOTE:** Clean, crushed, angular stone is also required around the perimeter of the system.

#### 5) Determine the volume of excavation (Ex) required. 6) Determine the area of filter fabric (F) required.

**Table 12 – Volume of Excavation Per Chamber**

|          | Stone Foundation Depth yd <sup>3</sup> (m <sup>3</sup> ) |             |             |
|----------|--|-------------|-------------|
|          | 6 (150 mm)   | 12 (300 mm) | 18 (450 mm) |
| SC-160LP | 1.5 (1.1)  | 1.8 (1.3)   | 2.1 (1.5)   |
| SC-310   | 2.9 (2.2)  | 3.4 (2.6)   | 3.8 (2.9)   |
| SC-740   | 5.5 (4.2)  | 6.2 (4.7)   | 6.8 (5.2)   |
|          | 9 (230 mm)   | 12 (300 mm) | 18 (450 mm) |
| DC-780   | 5.9 (4.5)  | 6.3 (4.8)   | 6.9 (5.3)   |

Note: Assumes 6" (150 mm) of separation between chamber rows (no spacing for the SC-160LP) and 18" (450 mm) of cover. The volume of excavation will vary as the depth of the cover increases.

**Each additional foot of cover will add a volume of excavation of 1.3 yds<sup>3</sup> (1.0 m<sup>3</sup>) per SC-740 / DC-780, 0.9 yds<sup>3</sup> (0.7 m<sup>3</sup>) per SC-310 chamber and 0.55 yds<sup>3</sup> (0.4m<sup>3</sup>) per SC-160LP chamber.**

The bottom and sides of the bed and the top of the embedment stone must be covered with ADS 601 (or equal) a non-woven geotextile (filter fabric). The area of the sidewalls must be calculated and a 2 foot (0.6 m) overlap must be included where two pieces of filter fabric are placed side-by-side or end-to-end. Geotextiles typically come in 15 foot (4.6 m) wide rolls.

#### 7) Determine the number of end caps (E.) required.

Each row of chambers requires two end caps.

$$E_c = \text{number of rows} \times 2$$

# 11.0 Detail Drawings

**Figure 16 - 4" PVC Inspection Port Detail (SC Series Chamber)**

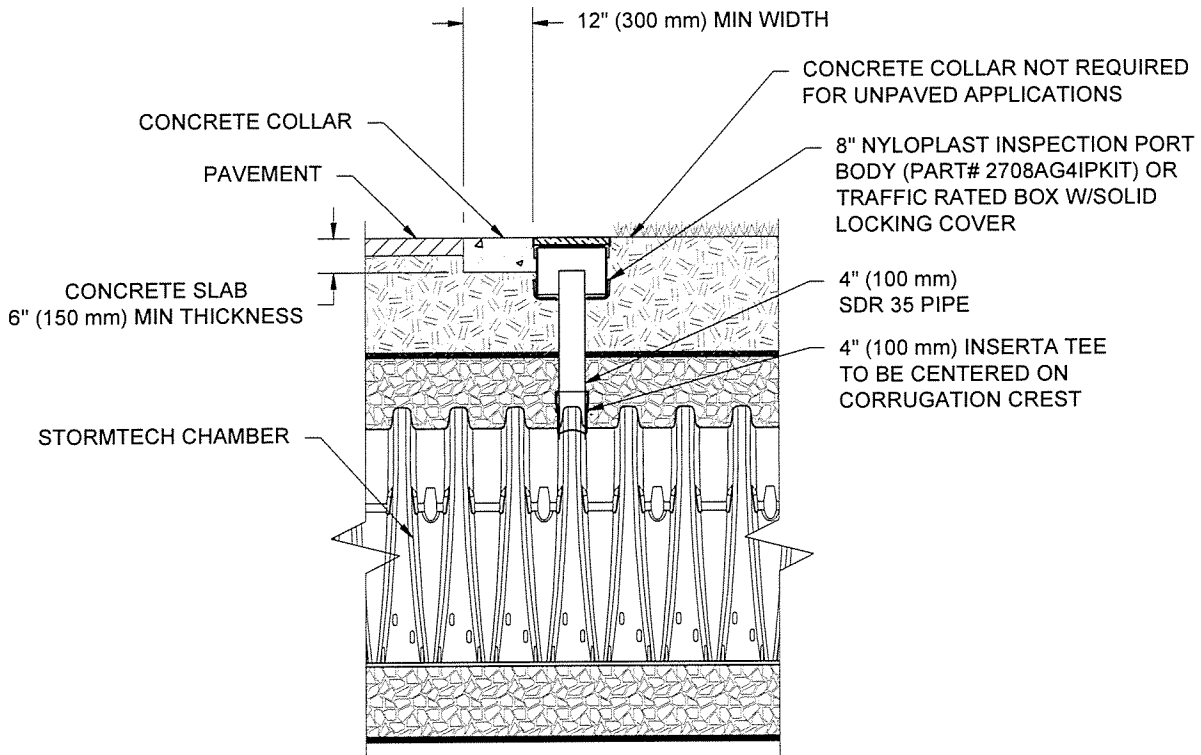

NOTE:  
INSPECTION PORTS MAY BE CONNECTED THROUGH ANY CHAMBER CORRUGATION CREST.

**Figure 17 - 6" Inspection Port Detail**

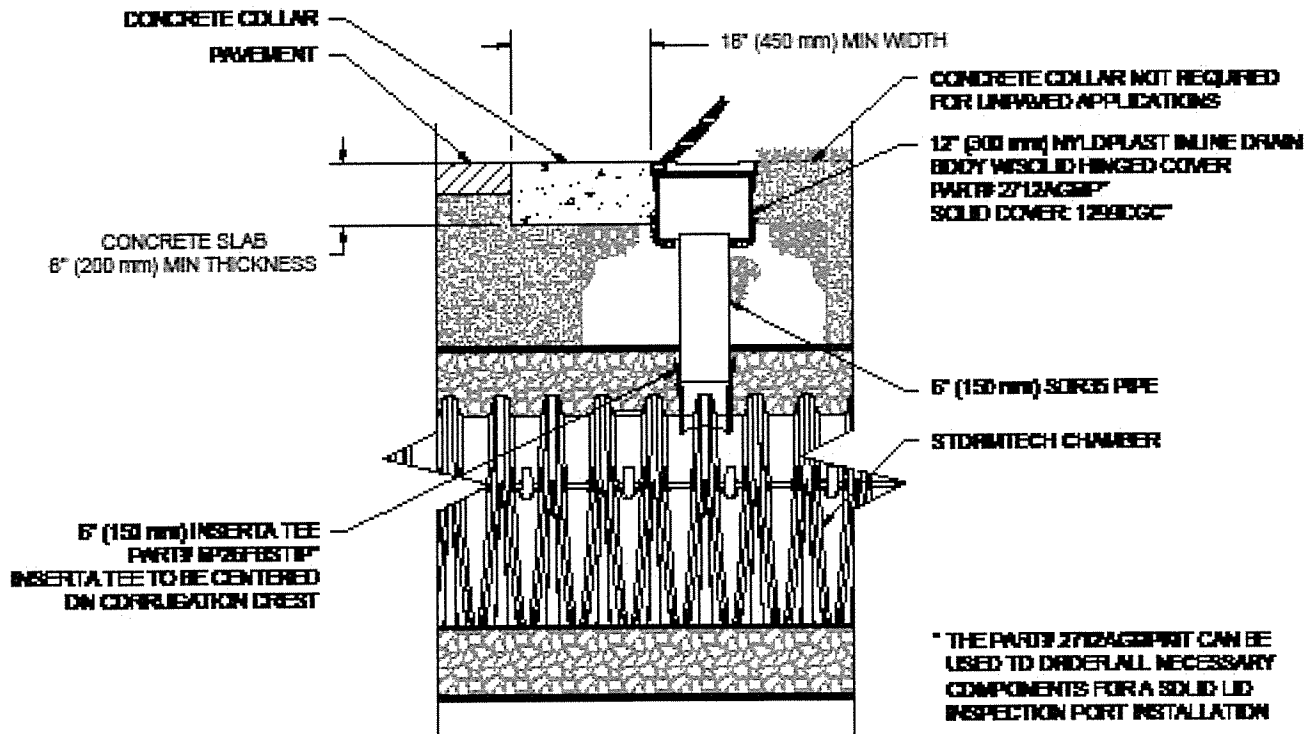

# 11.0 Detail Drawings

**Figure 18 – Under Drain Detail**

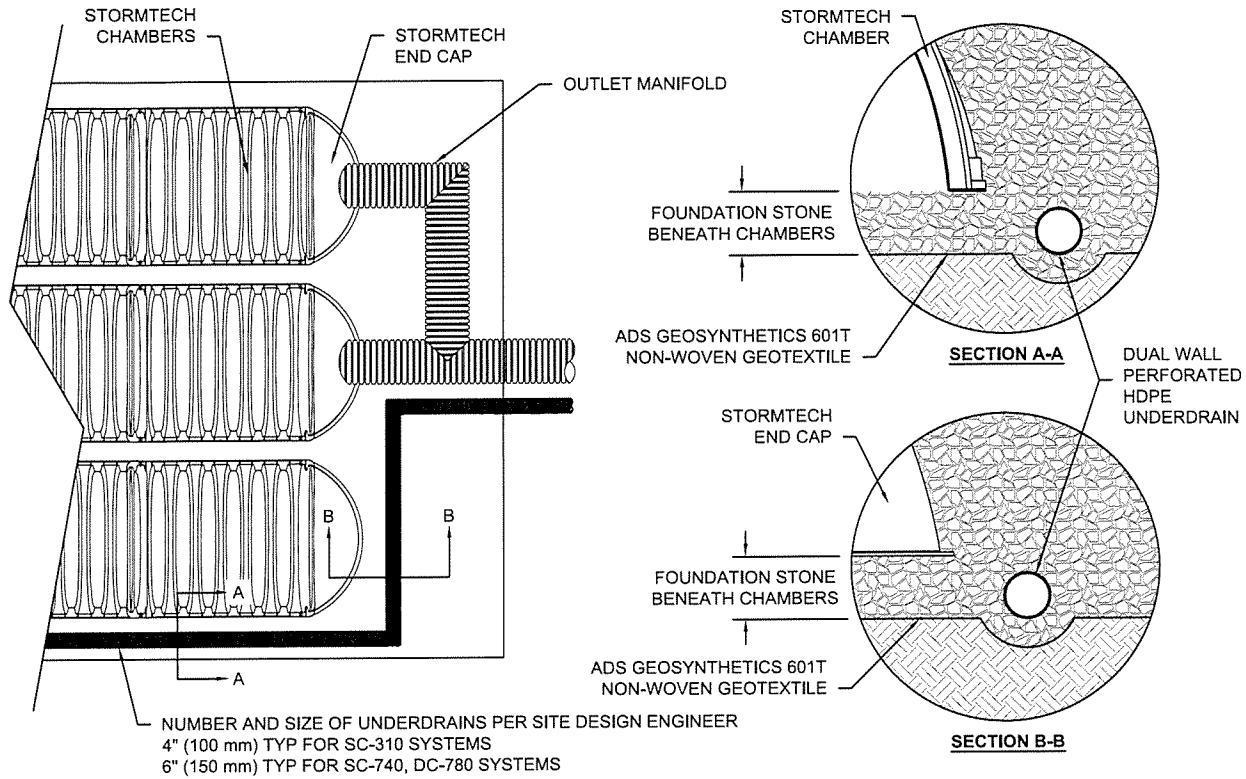

**Figure 19 – Inserta Tee Side Detail**

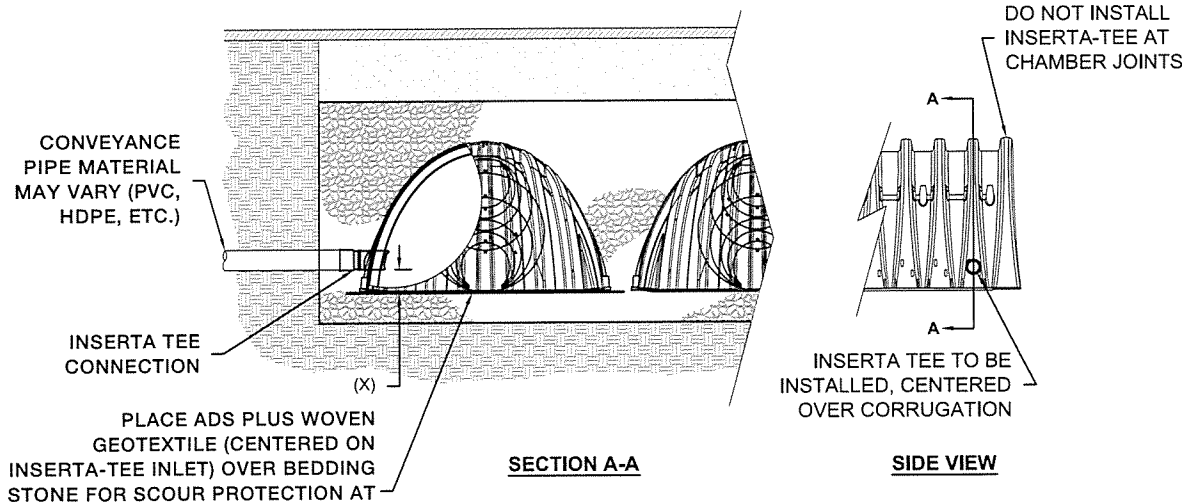

**NOTE:**  
PART NUMBERS WILL VARY BASED ON INLET PIPE MATERIALS. CONTACT STORMTECH FOR MORE INFORMATION.

| CHAMBER | MAX DIAMETER OF INSERTA TEE | HEIGHT FROM BASE OF CHAMBER (X) |
|---------|-----------------------------|---------------------------------|
| SC-310  | 6" (150 mm)                 | 4" (100 mm)                     |
| SC-740  | 10" (250 mm)                | 4" (100 mm)                     |
| DC-780  | 10" (250 mm)                | 4" (100 mm)                     |

INSERTA TEE FITTINGS AVAILABLE FOR SDR 26, SDR 36, SCH 40 IPS GASKETED & SOLVENT WELD, N-12, HP STORM, C-900 OR DUCTILE IRON.

**NOTE:** Side Inserta Tees Cannot be used on SC-160LP Chambers.

## 12.0 Inspection and Maintenance

### 12.1 Isolator Row Plus Inspection

Regular inspection and maintenance are essential to assure a properly functioning stormwater system. Inspection is easily accomplished through the manhole or optional inspection ports of an Isolator Row PLUS. Please follow local and OSHA rules for a confined space entry.

Inspection ports can allow inspection to be accomplished completely from the surface without the need for a confined space entry. Inspection ports provide visual access to the system with the use of a flashlight. A stadia rod may be inserted to determine the depth of sediment. If upon visual inspection it is found that sediment has accumulated to an average depth exceeding 3 (76 mm), cleanout is required.

A StormTech Isolator Row PLUS should initially be inspected immediately after completion of the site's construction. While every effort should be made to prevent sediment from entering the system during construction, it is during this time that excess amounts of sediments are most likely to enter any stormwater system. Inspection and maintenance, if necessary, should be performed prior to passing responsibility over to the site's owner. Once in normal service, a StormTech Isolator Row PLUS should be inspected bi-annually until an understanding of the sites characteristics is developed. The site's maintenance manager can then revise the inspection schedule based on experience or local requirements.

### 12.2 Isolator Row Plus Maintenance

JetVac maintenance is recommended if sediment has been collected to an average depth of 3 (76 mm) inside the Isolator Row PLUS. More frequent maintenance may be required to maintain minimum flow rates through the Isolator Row PLUS. The JetVac process utilizes a high pressure water nozzle to propel itself down the Isolator Row PLUS while scouring and suspending sediments. As the nozzle is retrieved, a wave of suspended sediments is flushed back into the manhole for vacuuming. Most sewer and pipe maintenance companies have vacuum/ JetVac combination vehicles. Fixed nozzles designed for culverts or large diameter pipe cleaning are preferable. Rear facing jets with an effective spread of at least 45 (1143 mm) are best. StormTech recommends a maximum nozzle pressure of 2000 psi be utilized during cleaning. The JetVac process shall only be performed on StormTech Rows that have ADS PLUS fabric over the foundation stone.

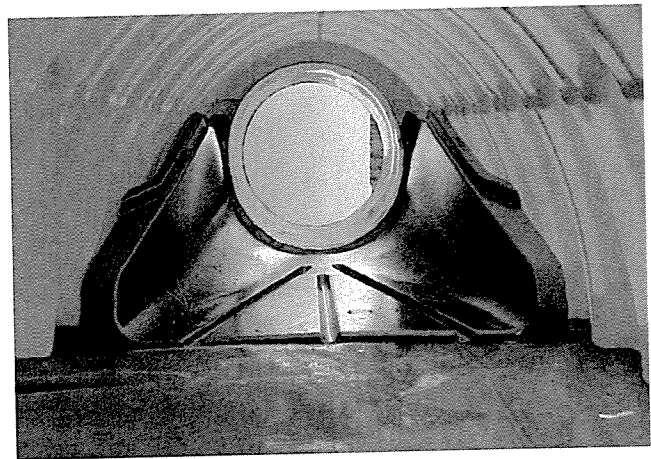

Looking down the Isolator Row PLUS



A typical JetVac truck (This is not a StormTech product.)

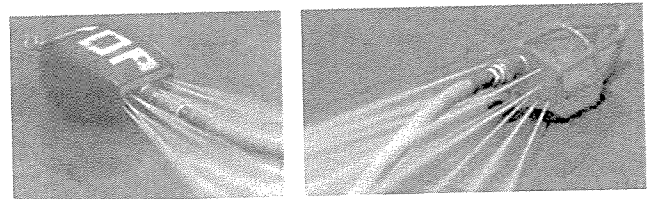
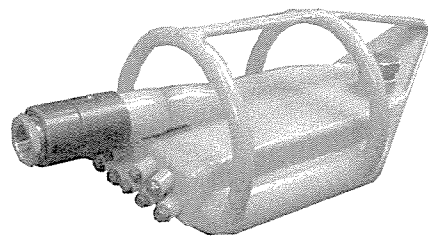

Examples of culvert cleaning nozzles appropriate for Isolator Row PLUS maintenance. (These are not StormTech products).



## 12.0 Inspection & Maintenance

### StormTech Isolator Row Plus - Step-by-Step Maintenance Procedures

#### Step 1: Inspect Isolator Row PLUS for sediment

- A) Inspection ports (if present)
  - i. Remove lid from floor box frame
  - ii. Remove cap from inspection riser
  - iii. Using a flashlight and stadia rod, measure depth of sediment
  - iv. If sediment is at, or above, 3" (76 mm) depth proceed to Step 2. If not proceed to Step 3.
- B) All Isolator Plus Rows
  - i. Remove cover from manhole at upstream end of Isolator Row PLUS
  - ii. Using a flashlight, inspect down Isolator Row PLUS through outlet pipe
    1. Follow OSHA regulations for confined space entry if entering manhole
    2. Mirrors on poles or cameras may be used to avoid a confined space entry
  - iii. If sediment is at or above the lower row of sidewall holes [approximately 3" (76 mm)] proceed to Step 2. If not proceed to Step 3.

#### Step 2: Clean out Isolator Row PLUS using the JetVac process

- A) A fixed floor cleaning nozzle with rear facing nozzle spread of 45 (1143 mm) or more is preferable
- B) Apply multiple passes of JetVac until backflush water is clean
- C) Vacuum manhole sump as required during jetting

#### Step 3: Replace all caps, lids and covers

#### Step 4: Inspect and clean catch basins and manholes upstream of the StormTech system following local guidelines.

Figure 20 - StormTech Isolator Row Plus (not to scale)

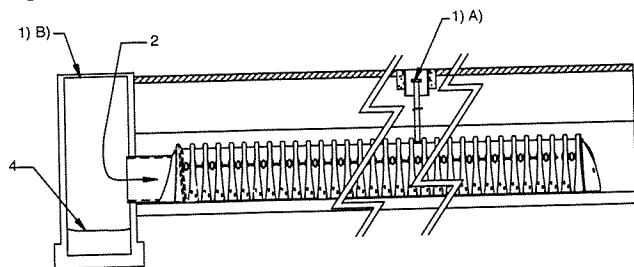

### 12.3 Eccentric Pipe Header Inspection

These guidelines do not supercede a pipe manufacturer's recommended I&M procedures. Consult with the manufacturer of the pipe header system for specific I&M procedures. Inspection of the header system should be carried out quarterly. On sites which generate higher levels of sediment more frequent inspections may be necessary. Headers may be accessed through risers, access ports or manholes. Measurement of sediment may be taken with a stadia rod or similar device. Cleanout of sediment should occur when the sediment volume has reduced the storage area by 25% or the depth of sediment has reached approximately 25% of the diameter of the structure.

### 12.4 Eccentric Pipe Manifold Maintenance

Cleanout of accumulated material should be accomplished by vacuum pumping the material from the header. Cleanout should be accomplished during dry weather. Care should be taken to avoid flushing sediments out through the outlet pipes and into the chamber rows.

### Eccentric Header Step-by-Step Maintenance Procedures

1. Locate manholes connected to the manifold system
2. Remove grates or covers
3. Using a stadia rod, measure the depth of sediment
4. If sediment is at a depth of about 25% pipe volume or 25% pipe diameter proceed to step 5. If not proceed to step 6.
5. Vacuum pump the sediment. Do not flush sediment out inlet pipes.
6. Replace grates and covers
7. Record depth and date and schedule next inspection

Figure 21 - Eccentric Manifold Maintenance

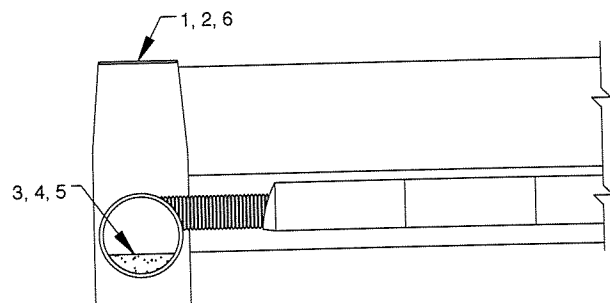

Please contact StormTech's Technical Services Department at 888-892-2894 for a spreadsheet to estimate cleaning intervals.

## 13.0 General Notes

1. StormTech requires installing contractors to use and understand StormTech's latest Installation Instructions prior to beginning system installation.
2. Our Technical Services Department offers installation consultations to installing contractors. Contact our Technical Service Representatives at least 30 days prior to system installation to arrange a preinstallation consultation. Our representatives can then answer questions or address comments on the StormTech chamber system and inform the Installing contractor of the minimum installation requirements before beginning the system's construction. Call **860-529-8188** to speak to a Technical Service Representative or visit **www.stormtech.com** to receive a copy of our Installation Instructions.
3. StormTech's requirements for systems with pavement design (asphalt, concrete pavers, etc.): Minimum cover for the SC-740, DC-780 and SC-310 chambers is 18" (457 mm) not including pavement; Minimum cover for the SC-160LP chamber is 14 (350 mm); Maximum cover for the SC-740 and SC-310 chambers is 96" (2.4 m) including pavement design; Maximum cover for the SC-160LP chamber is 10' (3.0 m); Maximum cover for the DC-780 chamber is 12' (3.6 m) including pavement design. For installations that do not include pavement, where rutting from vehicles may occur, minimum required cover is 24" (610 mm), maximum cover is as stated above.
4. The contractor must report any discrepancies with the bearing capacity of the chamber foundation materials to the design engineer.
5. AASHTO M288 Class 2 non-woven geotextile (filter fabric) must be used as indicated in the project plans.
6. Stone placement between chamber rows and around perimeter must follow instructions as indicated in the most current version of StormTech's Installation Instructions.
7. Backfilling over the chambers must follow requirements as indicated in the most current version of StormTech's Installation Instructions.
8. The contractor must refer to StormTech's Installation Instructions for a Table of Acceptable Vehicle Loads at various depths of cover. This information is also available at StormTech's website: **www.stormtech.com**. The contractor is responsible for preventing vehicles that exceed StormTech's requirements from traveling across or parking over the stormwater system. Temporary fencing, warning tape and appropriately located signs are commonly used to prevent unauthorized vehicles from entering sensitive construction areas.
9. The contractor must apply erosion and sediment control measures to protect the stormwater system during all phases of site construction per local codes and design engineer's specifications.
10. STORMTECH PRODUCT WARRANTY IS LIMITED. Contact StormTech for warranty information.

# 14.0 StormTech Product Specifications

## 1.0 General

1.1 StormTech chambers are designed to control storm water runoff. As a subsurface retention system, StormTech chambers retain and allow effective infiltration of water into the soil. As a subsurface detention system, StormTech chambers detain and allow for the metered flow of water to an outfall.

## 2.0 Chamber Parameters

- 2.1 The Chamber shall be injection molded of an impact modified polypropylene or polyethylene copolymer to maintain adequate stiffness through higher temperatures experienced during installation and service.
- 2.2 The nominal chamber dimensions of the StormTech SC-740 and DC-780 shall be 30.0 (762 mm) tall, 51.0 (1295 mm) wide and 90.7 (2304 mm) long. The nominal chamber dimensions of the StormTech SC-310 shall be 16.0 (406 mm) tall, 34.0 (864 mm) wide and 90.7 (2304 mm) long. SC-160LP shall be 12(305mm) tall, 25 (635 mm) wide and 90.7 (2304mm) long. The installed length of a joined chamber shall be 85.4 (2169 mm).
- 2.3 The chamber shall have a continuously curved section profile.
- 2.4 The chamber shall be open-bottomed.
- 2.5 The chamber shall incorporate an overlapping corrugation joint system to allow chamber rows of almost any length to be created. The overlapping corrugation joint system shall be effective while allowing a chamber to be trimmed to shorten its overall length.
- 2.6 The nominal storage volume of all StormTech chambers includes the volume of the clean, crushed, angular stone with an assumed 40% porosity. The nominal storage volume of a joined StormTech SC-740 chamber shall be 74.9 ft<sup>3</sup> (2.1 m<sup>3</sup>) per chamber when installed per StormTech's typical details. This equates to a storage volume per unit area of bed of 2.2 ft<sup>3</sup>/ft<sup>2</sup> (0.67 m<sup>3</sup>/m<sup>2</sup>). The nominal storage volume of a joined StormTech DC-780 chamber shall be 78.4 ft<sup>3</sup> (2.2 m<sup>3</sup>) per chamber when installed per StormTech's typical details. This equates to a storage volume per unit area of bed of 2.3 ft<sup>3</sup>/ft<sup>2</sup> (0.70 m<sup>3</sup>/m<sup>2</sup>). The nominal storage volume of a joined StormTech SC-310 chamber shall be 31.0 ft<sup>3</sup> (0.88 m<sup>3</sup>) per chamber when installed per StormTech's typical details. This equates to a storage volume per unit area of bed of 1.3 ft<sup>3</sup>/ft<sup>2</sup> (0.40 m<sup>3</sup>/m<sup>2</sup>). The nominal storage volume of a joined StormTech SC-160LP chamber shall be 15 ft<sup>3</sup> (0.42

m<sup>3</sup>) per chamber when installed per StormTech's typical details. This equates to a storage volume per unit area of bed of 1.0 ft<sup>3</sup>/ft<sup>2</sup> (0.30 m<sup>3</sup>/m<sup>2</sup>).

- 2.7 The SC-740 and SC-310 chambers shall have forty eight orifices penetrating the sidewalls to allow for lateral conveyance of water.
- 2.8 The chamber shall have two orifices near its top to allow for equalization of air pressure between its interior and exterior.
- 2.9 The chamber shall have both of its ends open to allow for unimpeded hydraulic flows and visual inspections down a row's entire length.
- 2.10 The chamber shall have 14 corrugations.
- 2.11 The chamber shall be analyzed and designed using AASHTO methods for thermoplastic culverts contained in the LRFD Bridge Design Specifications, 2<sup>nd</sup> Edition, including Interim Specifications through 2001. Design live load shall be the AASHTO design truck. Design shall consider earth and live loads as appropriate for the minimum to maximum specified depth of fill.
- 2.12 The chamber shall be manufactured in an ISO 9001:2000 certified facility.

## 3.0 End Cap Parameters

- 3.1 The end cap shall be designed to fit into any corrugation of a chamber, which allows: capping a chamber that has its length trimmed; segmenting rows into storage basins of various lengths.
- 3.2 The end cap shall have saw guides to allow easy cutting for various diameters of pipe that may be used to inlet the system.
- 3.3 The end cap shall have excess structural adequacies to allow cutting an orifice of any size at any invert elevation.
- 3.4 The primary face of an end cap shall be curved outward to resist horizontal loads generated near the edges of beds.
- 3.5 The end cap shall be manufactured in an ISO 9001:2000 certified facility.

# 15.0 Chamber Specifications for Contract Documents

## SC-160LP StormTech Chamber Specifications

1. Chambers shall be Stormtech SC-160LP.
2. Chambers shall be arch-shaped and shall be manufactured from virgin, impact-modified polypropylene copolymers.
3. Chambers shall meet the requirements of ASTM F2418-16A, Standard Specification for Polypropylene (PP) Corrugated Wall Stormwater Collection Chambers
4. Chamber rows shall provide continuous, unobstructed internal space with no internal supports that would impede flow or limit access for inspection.
5. The structural design of the chambers, the structural backfill, and the installation requirements shall ensure that the load factors specified in the AASHTO LRFD bridge design specifications, Section 12.12, are met for: 1) long-duration dead loads and 2) short-duration live loads, based on the AASHTO design truck with consideration for impact and multiple vehicle presences.
6. Chambers shall be designed, tested and allowable load configurations determined in accordance with ASTM F2787, Standard Practice for Structural Design of Thermoplastic Corrugated Wall Stormwater Collection Chambers. Load configurations shall include: 1) instantaneous (<1 min) AASHTO design truck live load on minimum cover 2) maximum permanent (75-yr) cover load and 3) allowable cover with parked (1-week) aashto design truck.
7. Requirements for handling and installation:
  - To maintain the width of chambers during shipping and handling, chambers shall have integral, interlocking stacking lugs.
8. Only chambers that are approved by the site design engineer will be allowed. The chamber manufacturer shall submit the following upon request to the site design engineer for approval before delivering chambers to the project site:
  - To ensure a secure joint during installation and backfill, the height of the chamber joint shall not be less than 1.5.
  - To ensure the integrity of the arch shape during installation, a) the arch stiffness constant as defined in section 6.2.8 of ASTM F2418 shall be greater than or equal to 400 lbs/in/in. And b) to resist softening during hot, sunny installation conditions, chambers shall be produced from light, reflective gold or yellow colors.
  - A structural evaluation sealed by a registered professional engineer that demonstrates that the safety factors are greater than or equal to 1.95 for dead load and 1.75 for live load, the minimum required by ASTM F2787 and by AASHTO for thermoplastic pipe.
  - A structural evaluation sealed by a registered professional engineer that demonstrates that the load factors specified in the AASHTO LRFD bridge design specifications, Section 12.12, are met. The 50 year creep modulus data specified in ASTM F2418 must be used as part of the AASHTO structural evaluation to verify long-term performance.

Chambers and end caps shall be produced at an ISO 9001 certified manufacturing facility.

## SC-310 StormTech Chamber Specifications

1. Chambers shall be Stormtech SC-310.
2. Chambers shall be arch-shaped and shall be manufactured from virgin, impact-modified polypropylene or polyethylene copolymers.
3. Chambers shall meet the requirements of ASTM F2922 (polyethylene) or ASTM F2418-16A (polypropylene), Standard Specification for Corrugated Wall Stormwater Collection Chambers
4. Chamber rows shall provide continuous, unobstructed internal space with no internal supports that would impede flow or limit access for inspection.
5. The structural design of the chambers, the structural backfill, and the installation requirements shall ensure that the load factors specified in the AASHTO LRFD bridge design specifications, Section 12.12, are met for: 1) long-duration dead loads and 2) short-duration live loads, based on the AASHTO design truck with consideration for impact and multiple vehicle presences.
6. Chambers shall be designed, tested and allowable load configurations determined in accordance with ASTM F2787, Standard Practice for Structural Design of Thermoplastic Corrugated Wall Stormwater Collection Chambers. Load configurations shall include: 1) instantaneous (<1 min) AASHTO design truck live load on minimum cover 2) maximum permanent (75-yr) cover load and 3) allowable cover with parked (1-week) AASHTO to design truck.
7. Requirements for handling and installation:
  - To maintain the width of chambers during shipping and handling, chambers shall have integral, interlocking stacking lugs.
8. Only chambers that are approved by the site design engineer will be allowed. The chamber manufacturer shall submit the following upon request to the site design engineer for approval before delivering chambers to the project site:
  - To ensure a secure joint during installation and backfill, the height of the chamber joint shall not be less than 2.
  - To ensure the integrity of the arch shape during installation, a) the arch stiffness constant as defined in Section 6.2.8 of ASTM F2418 shall be greater than or equal to 400 lbs/in/in. And b) to resist softening during hot, sunny installation conditions, chambers shall be produced from light, reflective gold or yellow colors.
  - A structural evaluation sealed by a registered professional engineer that demonstrates that the safety factors are greater than or equal to 1.95 for dead load and 1.75 for live load, the minimum required by ASTM F2787 and by AASHTO for thermoplastic pipe.
  - A structural evaluation sealed by a registered professional engineer that demonstrates that the load factors specified in the AASHTO LRFD bridge design specifications, Section 12.12, are met. The 50 year creep modulus data specified in ASTM F2418 must be used as part of the aashto structural evaluation to verify long-term performance.

Chambers and end caps shall be produced at an ISO 9001 certified manufacturing facility.

# 15.0 Chamber Specifications for Contract Documents

## SC-740 StormTech Chamber Specifications

1. Chambers shall be Stormtech SC-740.
  2. Chambers shall be arch-shaped and shall be manufactured from virgin, impact-modified polypropylene copolymers.
  3. Chambers shall meet the requirements of ASTM F2418-16A, Standard Specification for Polypropylene (PP) Corrugated Wall Stormwater Collection Chambers
  4. Chamber rows shall provide continuous, unobstructed internal space with no internal supports that would impede flow or limit access for inspection.
  5. The structural design of the chambers, the structural backfill, and the installation requirements shall ensure that the load factors specified in the AASHTO LRFD bridge design specifications, Section 12.12, are met for: 1) long-duration dead loads and 2) short-duration live loads, based on the AASHTO design truck with consideration for impact and multiple vehicle presences.
  6. Chambers shall be designed, tested and allowable load configurations determined in accordance with ASTM F2787, Standard practice for structural design of Thermoplastic Corrugated Wall Stormwater Collection Chambers. Load configurations shall include: 1) instantaneous (<1 min) AASHTO design truck live load on minimum cover 2) maximum permanent (75-yr) cover load and 3) allowable cover with parked (1-week) AASHTO design truck.
  7. Requirements for handling and installation:
    - To maintain the width of chambers during shipping and handling, chambers shall have integral, interlocking stacking lugs.
  8. Only chambers that are approved by the site design engineer will be allowed. The chamber manufacturer shall submit the following upon request to the site design engineer for approval before delivering chambers to the project site:
    - A structural evaluation sealed by a registered professional engineer that demonstrates that the safety factors are greater than or equal to 1.95 for dead load and 1.75 for live load, the minimum required by ASTM F2787 and by AASHTO for thermoplastic pipe.
    - A structural evaluation sealed by a registered professional engineer that demonstrates that the load factors specified in the AASHTO LRFD bridge design specifications, Section 12.12, are met. The 50 year creep modulus data specified in ASTM F2418 must be used as part of the AASHTO structural evaluation to verify long-term performance.
- Chambers and end caps shall be produced at an ISO 9001 certified manufacturing facility.

## DC-780 StormTech Chamber Specifications

1. Chambers shall be Stormtech DC-780.
  2. Chambers shall be arch-shaped and shall be manufactured from virgin, impact-modified polypropylene copolymers.
  3. Chambers shall meet the requirements of ASTM F2418-16A, Standard Specification for Polypropylene (PP) Corrugated Wall Stormwater Collection Chambers
  4. Chamber rows shall provide continuous, unobstructed internal space with no internal supports that would impede flow or limit access for inspection.
  5. The structural design of the chambers, the structural backfill, and the installation requirements shall ensure that the load factors specified in the AASHTO LRFD bridge design specifications, Section 12.12, are met for: 1) long-duration dead loads and 2) short-duration live loads, based on the AASHTO design truck with consideration for impact and multiple vehicle presences.
  6. Chambers shall be designed, tested and allowable load configurations determined in accordance with ASTM F2787, Standard Practice for Structural Design of Thermoplastic Corrugated Wall Stormwater Collection Chambers. Load configurations shall include: 1) instantaneous (<1 min) AASHTO design truck live load on minimum cover 2) maximum permanent (75-yr) cover load and 3) allowable cover with parked (1-week) AASHTO design truck.
  7. Requirements for handling and installation:
    - To maintain the width of chambers during shipping and handling, chambers shall have integral, interlocking stacking lugs.
  8. Only chambers that are approved by the site design engineer will be allowed. The chamber manufacturer shall submit the following upon request to the site design engineer for approval before delivering chambers to the project site:
    - To ensure a secure joint during installation and backfill, the height of the chamber joint shall not be less than 2.
    - To ensure the integrity of the arch shape during installation, a) the arch stiffness constant as defined in Section 6.2.8 of ASTM F2418 shall be greater than or equal to 550 lbs/in/in. And b) to resist softening during hot, sunny installation conditions, chambers shall be produced from light, reflective gold or yellow colors.
- Chambers and end caps shall be produced at an ISO 9001 certified manufacturing facility.

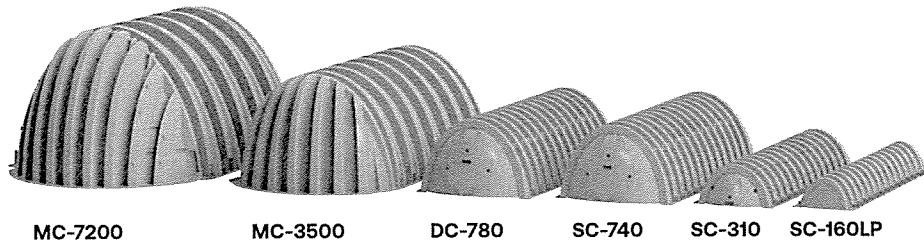

## **A Family of Products and Services for the Stormwater Industry:**

MC-3500 and MC-7200 Chambers and End Caps  
SC-160LP, SC-310 and SC-740 Chambers & End Caps  
DC-780 Chambers and End Caps  
Fabricated End Caps  
Fabricated Manifold Fittings  
Patented Isolator Row PLUS for Maintenance and  
Water Quality  
Chamber Separation Spacers  
In-House System Layout Assistance  
On-Site Educational Seminars  
Worldwide Technical Sales Group  
Centralized Product Applications Department  
Research and Development Team  
Technical Literature, O&M Manuals and Detailed CAD  
drawings all downloadable via our Website

**StormTech provides state-of-the-art products and services that meet or exceed industry performance standards and expectations. We offer designers, regulators, owners and contractors the highest quality products and services for stormwater management that Saves Valuable Land and Protects Water Resources.**

**adspipe.com**  
800-821-6710